

7600-E THERMOSTATIC Showermaster® INSTALLATION INSTRUCTIONS

Valve is ASSE 1016 T/P Listed

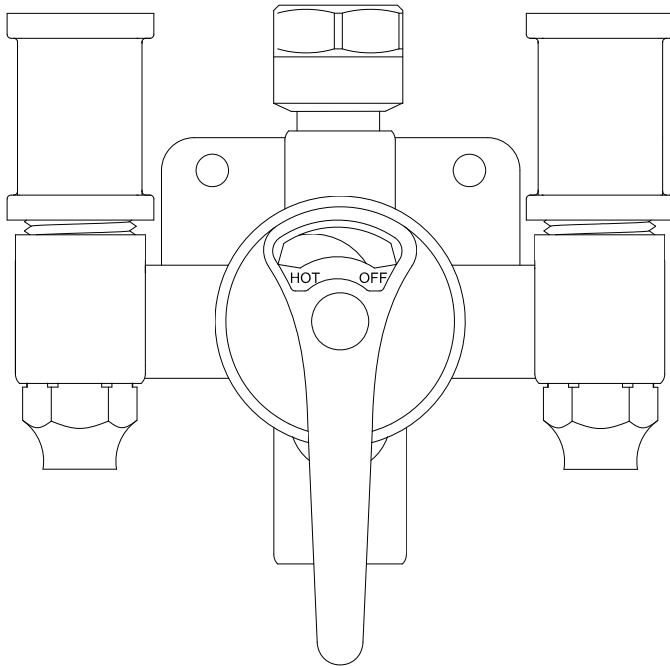

1. Valve must **NOT** be sealed in wall with plaster or tile. Inlet fittings **MUST** be accessible for servicing.
2. Install hot to left inlet and cold to right inlet (see H and C marks on valve body).
3. Pipe cement, or solder flux must be used sparingly. After connections are made to the valve, flush pipes thoroughly (remove internal parts if necessary) to eliminate dirt and excess materials, which might become lodged in the working parts of the valve.
4. **IMPORTANT!** The exposed 7600-E valve is designed for top and bottom outlet. When used for showers, the top outlet only is used and the pipe plug is left in the bottom outlet. When used for shower AND tub, remove the pipe plug from the bottom outlet and pipe down to a diverter tub spout. No special elbow is required, (see installation drawings, page 4).
5. After the valve is installed as noted above, recheck and reset the adjustable high temperature limit stop (see instructions, page 2).

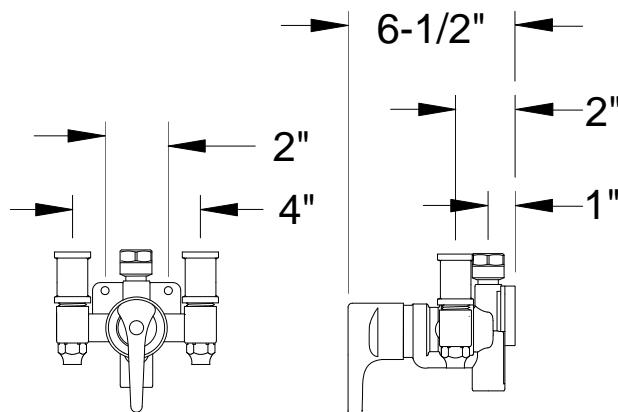

REMEMBER!! THIS IS A CONTROL DEVICE WHICH MUST BE CLEANED AND MAINTAINED ON A REGULAR BASIS (SEE MAINTENANCE GUIDE AND RECORD MGR-1000).

OPERATION

The 7600 is a thermostatic water-mixing valve, which will compensate for changes in the temperature or pressure of hot and cold supplies and maintain bathing temperatures. Turn the handle counter-clockwise from the "OFF" position through the (COLD) area on the dial plate, the shower is on and temperature is cold. As the handle is turned toward the RED (HOT) area, shower temperature becomes progressively WARMER until the high temperature limit is reached in the full "HOT" position. To turn OFF move handle back in clockwise direction to the "OFF" position. This thermostatic device must be cycled prior to use. While running water, simply adjust the outgoing temperature from full hot to full cold a minimum of ten (10) times. This ensures that the wax element has been fully flexed. Once flexed, the unit no longer requires any further cycling.

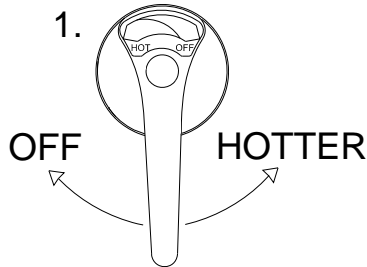

SERVICING INSTRUCTIONS

1. Remove snap cap (1018), screw (39) and washer (244). Remove pointer (7918), washer (7939) and tension spring (7936).
2. Turn off hot and cold supplies to the valve (using the inlet stops or checkstops furnished).
3. Remove the cover assembly (7970) and release the cover and control assembly (DWG. 4). Remove shuttle assembly.
4. To clean, submerge the assemblies in clear, warm water to remove deposit or stain. Use a mild solution of household vinegar or non-corrosive cleaning solution to remove stubborn deposits. Replace the assembly, and reset high temperature limit stop (DWG. 3).
5. When cleaning the assemblies, **DO NOT USE ABRASIVES. LUBRICATE THE SHUTTLE O'RINGS.**
6. Return complete assembly to valve base, use medium strength Loctite 242 on cover threads and tighten cover, **NOTE TEMPERATURE LIMIT STOP MUST BE RESET AFTER REASSEMBLY!**

WARNING

WARNING! THIS MIXING VALVE IS EQUIPPED WITH AN ADJUSTABLE HIGH TEMPERATURE LIMIT STOP FACTORY SET AT APPROXIMATELY 110°F (43°C) WITH AN INCOMING HOT WATER SUPPLY TEMPERATURE OF 135°F (57°C). IF INCOMING HOT WATER ON THE JOB IS HIGHER THAN 135°F, THE VALVE WHEN TURNED TO THE FULL HOT MAY DELIVER WATER IN EXCESS OF 110°F, AND THE HIGH TEMPERATURE LIMIT STOP MUST BE RESET BY THE INSTALLER. (SEE BELOW)

WARNING! HOT WATER OVER 110°F (43°C) IS DANGEROUS AND MAY CAUSE SCALDING!

TO RESET HIGH TEMPERATURE LIMIT STOP (DWG. 3):

1. Turn pointer to the left or right until valve is delivering the highest desired temperature of 110°F (43°C) or lower.
2. Remove pointer from spline. Install Tension Spring onto stem.
3. Replace pointer on the spline with the STOP, which is cast into the underside of the pointer, resting against the TOP side of the WEB STOP which is located on the cover of the valve.
4. If properly adjusted, the pointer should now move freely from the HOT position, clockwise to the OFF position.

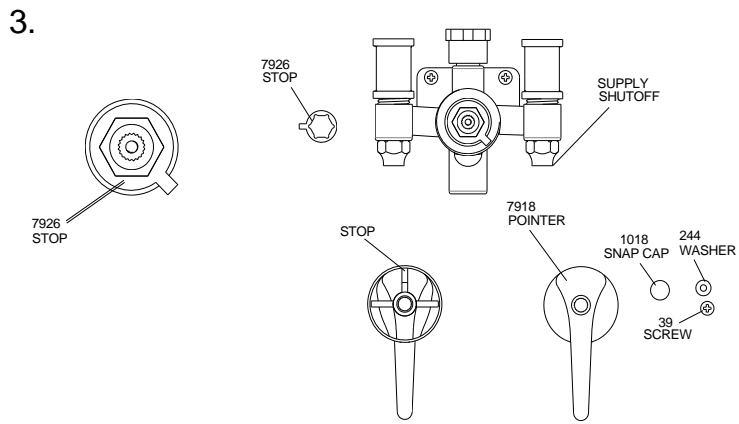
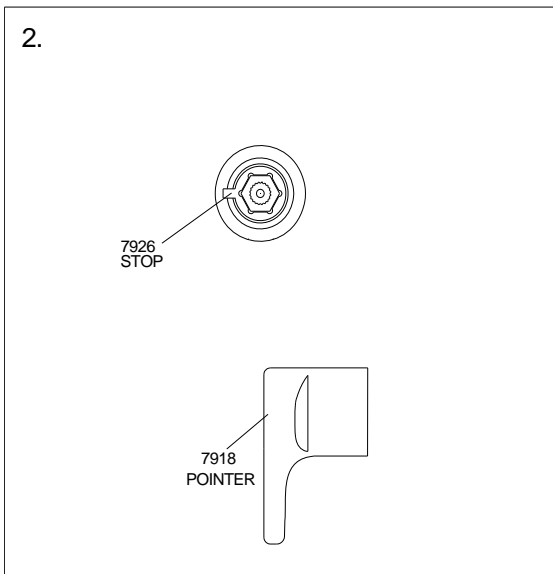

REMEMBER!! THIS IS A CONTROL DEVICE WHICH MUST BE CLEANED AND MAINTAINED ON A REGULAR BASIS (SEE MAINTENANCE GUIDE AND RECORD MGR-1000).

PARTS/ASSEMBLY

4.

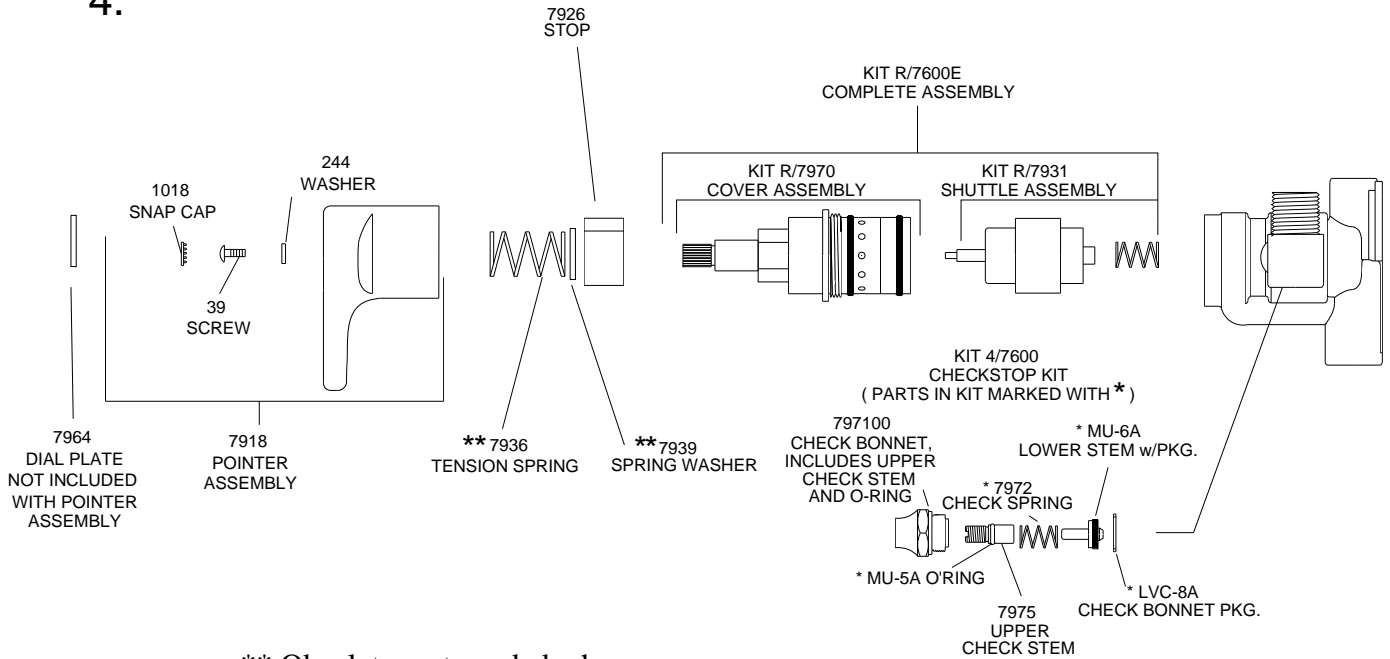

** Obsolete, not needed when purchasing new KIT R/7970 or KIT R/7600E

SERVICING INSTRUCTIONS

| DESCRIPTION | SYMPTOM | KIT REQUIRED | |
|--------------------|--|--|--|
| PACKINGS & GASKETS | <ol style="list-style-type: none"> 1. Leak at handle or cover. 2. Valve will not shut off completely. 3. Valve is difficult to pull apart. | Kit1/7600 | Cover o' ring (2) Lower o' rings Shuttle o' ring Spring washer Shut off gasket |
| COVER ASSEMBLY | <ol style="list-style-type: none"> 4. After packings and gaskets have been replaced, valve will not shut off completely. 5. Valve does not respond when handle is turned. | Kit R/7970 or Complete Rebuild Kit R/7600E | Complete cover assembly |
| SHUTTLE ASSEMBLY | <ol style="list-style-type: none"> 6. After replacing packings and gaskets, valve will not hold temperature or delivers full hot or full cold. | Kit R/7931 or Complete Rebuild Kit R/7600E | Shuttle, wax element and spring |
| CHECKSTOPS, STOPS | <ol style="list-style-type: none"> 7. Supplies cannot be shut off completely. 8. Leak at checkstops (or stop) bonnet or stem. 9. Hot water is crossing into cold or vise versa. | Kit 4/7600 | (2 each) MU-6A,7972, MU-5A, LVC-8A |

INSTALLATION

SS-7600-103-E

SS-7600-101-E

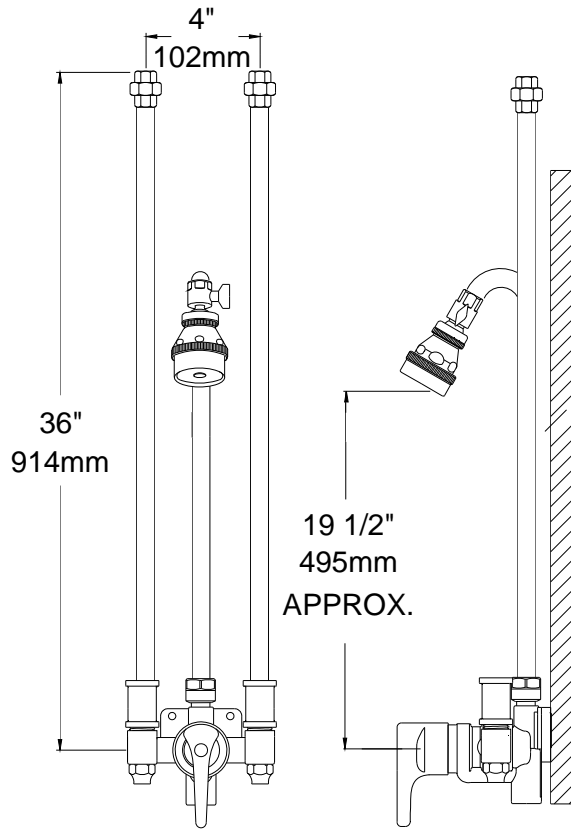
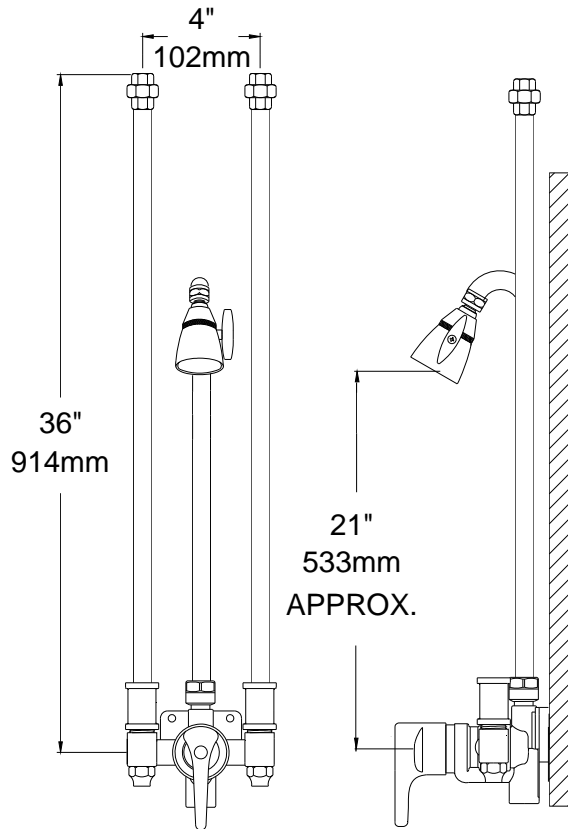

LIMITED WARRANTY

Leonard Valve Company (hereinafter, "Leonard") warrants the original purchaser that products manufactured by Leonard will be free from defects in material or workmanship under normal conditions of use, when properly installed and maintained in accordance with Leonard's instructions, for a period of one year from the date of shipment. During this period, Leonard will at its option repair or replace any product, or part thereof, which shall be returned, freight prepaid, to the Leonard factory and determined by Leonard to be defective in materials or workmanship. Leonard provides no warranty, express or implied, which extends beyond the description contained herein. LEONARD SPECIFICALLY DISCLAIMS ANY AND ALL IMPLIED WARRANTIES OF MERCHANTABILITY OR OF FITNESS FOR A PARTICULAR PURPOSE. Nonetheless, some jurisdictions may not allow the disclaimer of certain implied warranties, in which case Leonard hereby limits such implied warranties to the duration of the limited warranty period contained herein. Some jurisdictions may not allow limitations on how long an implied warranty lasts, so the foregoing durational limitation may not apply to you. In no event will Leonard be liable for labor or incidental or consequential damages. Any alteration or improper installation or use of this product will void this limited warranty. If any provision of this limited warranty is prohibited by law in the applicable jurisdiction, such provision shall be null and void, but the remainder of this limited warranty shall continue in full force and effect.

1360 Elmwood Avenue, Cranston, RI 02910 USA

Phone: 401.461.1200 Fax: 401.941.5310

Email: info@leonardvalve.com

Web Site: <http://www.leonardvalve.com>