

LV477B-3 METERING VALVE

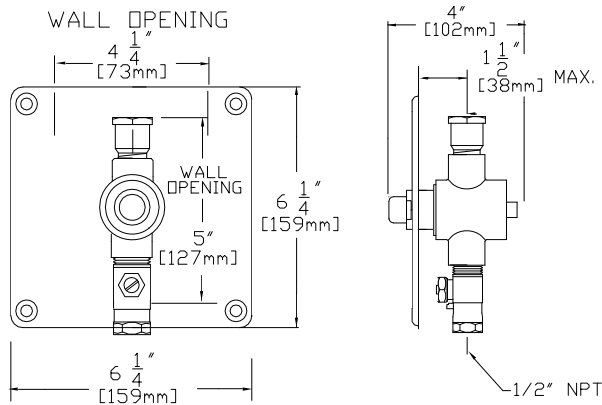

Leonard LV477B-3 Metering Valve pushbutton- type, for concealed piping, 1/2" connections.

Brass body, exposed parts chrome plated and polished stainless steel.

Fixed cycle (approximately 30 seconds) +5 sec. -10 sec. subject to site conditions.

Recommended Maximum Operating Pressure: 80 PSIG (550 KPA)

Inlet stop, 1/2" NPT.

Recommended Maximum Operating Temperature: 105°F (41°C) recommended for bathing comfort. **NOTE:** Specify a properly sized Leonard Thermostatic Water Mixing Valve to temper the water supply to the metering valve(s).

770/770BL VOLUME CONTROL

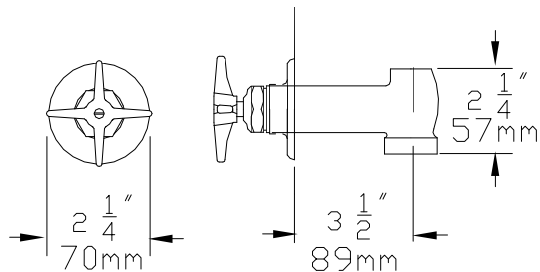

770

Concealed compression type volume control on/off valve

Four arm handle

Exposed parts chrome plated

1/2" IPS connections

770BL- Same as above but with lever type handle

| | |
|---|---|
| <p>Engineer's Approval</p> | <p>Job # _____</p> <p>Arch/Eng. _____</p> <p>Contractor _____</p> |
|---|---|