

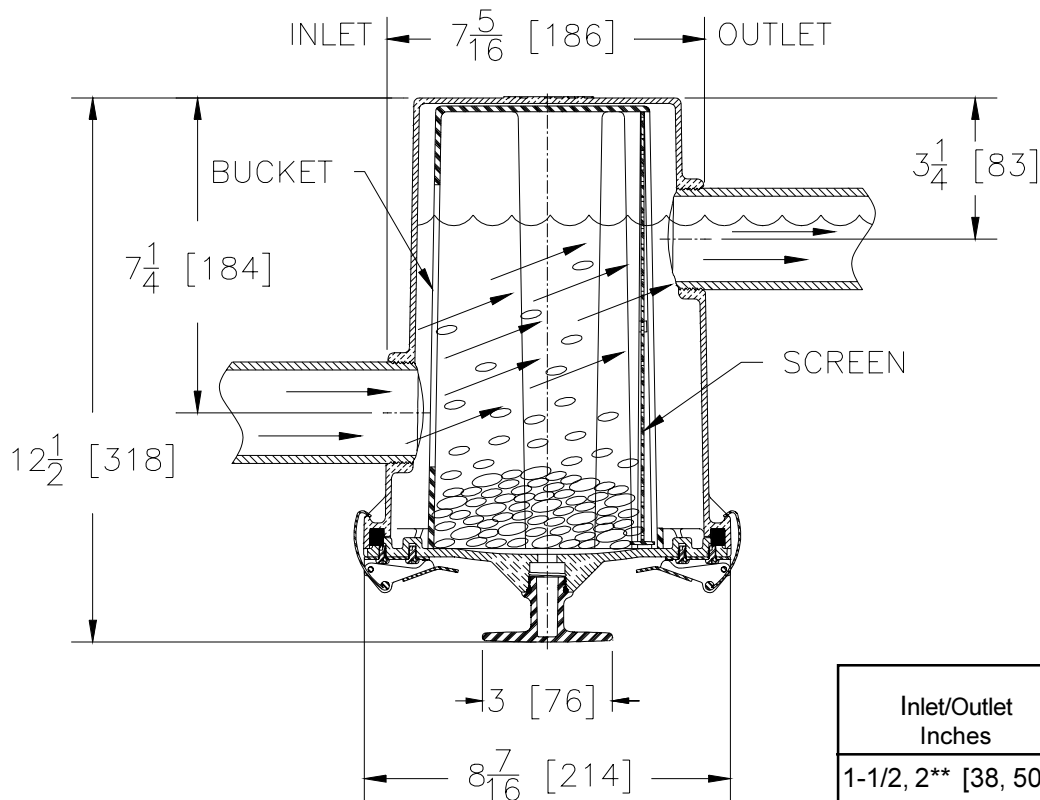

Z-1184 SOLIDS INTERCEPTOR

Operation and Maintenance Instructions



| Inlet/Outlet Inches | Flow Rate GPM [L] | Approx. Wt. Lbs. [kg] |
|---------------------|-------------------|-----------------------|
| 1-1/2, 2** [38, 50] | 15 [57] | 6 [3] |

SIZING

There are no sizing requirements for this interceptor, except to specify the inlet and outlet size. All units are made with a standard 2 [51] pipe size inlet and outlet, reduced to 1 1/2 [38] with a bushing when specified and are capable of handling drainage volumes standard to their respective pipe size.

DESIGN

The Zurn Z-1184 Solids Interceptor is designed to recover all types of solids from precious metal particles, to plaster, clay or similar materials. This is accomplished through the principal of gravity separation. Particles of various sizes and weights are trapped in the bucket.

OPERATION

The waste water flows from the inlet piping into the removable bucket, passing through the screen, into the main body chamber, then exits the interceptor to the sanitary drain system.

MAINTENANCE

Cleaning should be done on a regular basis, either before or after the bucket becomes clogged. First remove the handle in the center of the cover and drain out the water in the interceptor, replace handle. Then unlatch and remove the cover/bucket assembly, twist and lift the bucket to remove from cover, take out the screen and clean out all debris. Replace the screen in the bucket, next place the bucket back on the cover and twist to reattach. Make certain cover gasket is intact and clean. Apply a light coating of oil on the cover gasket, which helps prevent cover gasket from adhering to cover and aids in maintaining a complete seal. The cover/bucket assembly should then be placed back in the unit, **MAKING SURE THE SCREEN IN THE BUCKET IS ON THE OUTLET SIDE AS SHOWN**, and relatch to secure cover. Efficiency of operation is directly related to the level of maintenance.