



Z1717 SCUPPER DRAIN

SPECIFICATION SHEET

TAG _____

Dimensional Data (inches and [mm]) are Subject to Manufacturing Tolerances and Change Without Notice

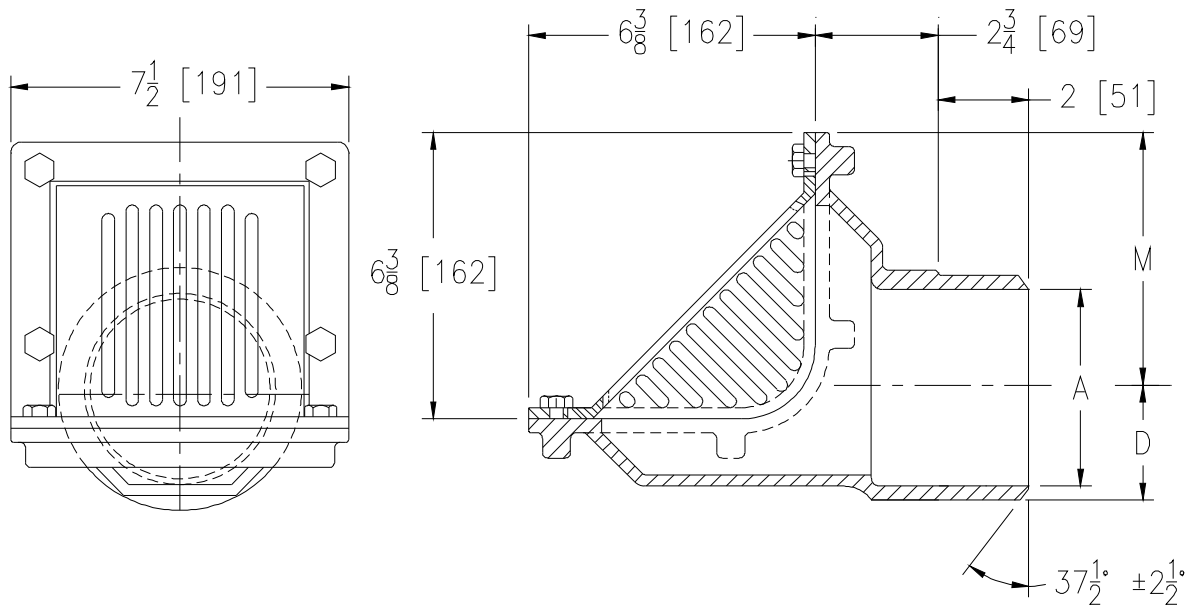

Dimensions in Inches			Approx. Wt. Lbs. [kg]	Grate Open Area Sq. In. [cm ²]
A- Pipe Size	D	M		
3 [75]	2 [51]	6-1/8 [156]	24 [11]	20 [129]
4 [102]	2-1/2 [63]	5-5/8 [143]		

ENGINEERING SPECIFICATION: ZURNZ1717
Scupper drain with Type 304 (CF8) stainless steel body and cast aluminum oblique grate and clamp collar.

OPTIONS (Check/specify appropriate options)

PIPE SIZE

3-4 [76-102]

(Specify size) **OUTLET**

_____ BW Butt-weld
(Specify Schedule 10,40 or 80)

PREFIXES

- _____ Z Type 304 (CF8) Stainless Steel Body*
- _____ ZM Type 316 (CF8M) Stainless Steel Body

OPTIONS

- _____ -VP Vandal-Proof Secured Top

REV. D	DATE: 11/15/10	C.N. NO. 120382
DWG. NO. 59287		PRODUCT NO. Z1717

*REGULARLY FURNISHED UNLESS OTHERWISE SPECIFIED