

AQUASPEC® FAUCETS

MODEL - Z82200 SERIES
SINGLE CONTROL FAUCET



TECHNICAL INFORMATION

FLOW: 2.2 GPM [8.3L] PRESSURE COMPENSATING AERATOR*

MAXIMUM PRESSURE: 125 PSI

MAXIMUM TEMPERATURE: 180° F

CARTRIDGE STYLE - CERAMIC DISC MIXING CARTRIDGE WITH TEMPERATURE LIMIT STOP

* AN AERATOR WITH A MAXIMUM FLOW RATE OF 2.2 GPM (8.3L/min) MUST BE INSTALLED FOR THIS FAUCET MODEL TO MEET THE REQUIREMENTS OF CSA B125.1/ASME A112.18.1

IMPORTANT THE WATER SUPPLY LINES MUST BE THOROUGHLY FLUSHED BEFORE INSTALLATION TO PREVENT FOREIGN MATTER AND DEBRIS FROM CLOGGING AND/OR DAMAGING INTERNAL COMPONENTS AND THEREBY PREVENTING THE FAUCET FROM FUNCTIONING PROPERLY

INSTALLATION INSTRUCTIONS

1. SECURE GASKET (ITEM # 9A) WITH ADHESIVE BACKING TO UNDERSIDE OF FAUCET BODY.
2. PLACE FAUCET ON SINK THROUGH PRE-DRILLED MOUNTING HOLE IN SINK.
3. PLACE MOUNTING RING (ITEM #9C) ONTO MOUNTING STUD (ITEM #7). FLAT SIDE OF MOUNTING RING SHOULD FACE UNDERSIDE OF SINK.
4. ROTATE FAUCET BODY (ITEM #5) TO DESIRED ALIGNMENT AND SECURE TO SINK USING MOUNTING NUT (ITEM #9B) ON MOUNTING STUD (ITEM #7). HEX SIDE OF MOUNTING NUT SHOULD FACE DOWN TO ALLOW ACCESS TO HEX NUT AND/OR SCREW SLOT. **DO NOT OVER TIGHTEN.**
5. INSTALL HANDLE (ITEM #1A)
 - 5.1. REMOVE COLORED HOT/COLD INDEX (ITEM #1C) FROM HANDLE BY PRESSING OUT FROM UNDERSIDE OF HANDLE (ITEM #1A)
 - 5.2. LOOSEN SETSCREW (ITEM #1B) USING 1/8" ALLEN WRENCH.
 - 5.3. SLIDE HANDLE ONTO STEM OF CERAMIC MIXING CARTRIDGE (ITEM #4)
 - 5.4. TIGHTEN SETSCREW (ITEM #1B) USING 1/8" ALLEN WRENCH. DO NOT OVER TIGHTEN.
 - 5.5. PRESS COLORED HOT/COLD INDEX (ITEM #1C) INTO HANDLE.
6. ATTACH LAVATORY SUPPLIES TO BRAIDED FLEX HOSES (ITEM #8)
7. OPTIONAL:
POP-UP DRAIN (-P)
GRID STRAINER DRAIN (-G)

INSTALL POP-UP DRAIN OR GRID STRAINER DRAIN IN SINK OUTLET AND PLUMB WASTE CONNECTION.
8. TURN SUPPLY WATER ON AND OPERATE FAUCET CHECKING FOR LEAKS.
9. INSTALL AERATOR INTO FAUCET AND HAND TIGHTEN INTO FAUCET SPOUT. IT MAY BE NECESSARY TO REMOVE AND CLEAN THE AERATOR AT START UP.

MAINTENANCE

1. YOUR ZURN FAUCET HAS A HIGHLY POLISHED NICKEL CHROME PLATED FINISH. CLEAN WITH SOAP AND WATER OR A MILD CLEANER WHICH IS SAFE FOR CHROME PLATING. DO NOT USE ACIDS OR TOILET BOWL CLEANER AS THEY WILL DAMAGE THE FINISH.
2. AQUASPEC FAUCETS CONTAIN CERAMIC MIXING CARTRIDGES WHICH REQUIRE NO MAINTENANCE. TO REMOVE AND REPLACE THE CARTRIDGE:
 - 2.1. REMOVE HOT/COLD INDEX BUTTON (ITEM #1C) BY CAREFULLY PRYING LOOSE FROM UNDERSIDE OF HANDLE (ITEM #1A)
 - 2.2. LOOSEN SET SCREW (ITEM # 1B) IN HANDLE
 - 2.3. REMOVE HANDLE FROM CARTRIDGE STEM
 - 2.4. LOOSEN AND REMOVE DOMED CARTRIDGE FLANGE (ITEM # 2)
 - 2.5. LOOSEN AND REMOVE CARTRIDGE RETAINING NUT (ITEM #3)
 - 2.6. PULL CERAMIC MIXING CARTRIDGE (ITEM #4) BY PULLING ON STEM WHILE WIGGLING FROM SIDE-TO-SIDE
 - 2.7. INSTALL NEW CARTRIDGE USING THE ALIGNMENT PINS FOR PROPER ORIENTATION AND PROPER SEATING IN THE FAUCET BODY.
 - 2.8. REINSTALL HANDLE ASSEMBLY BY REVERSING STEPS 2.1 THROUGH 2.5.
3. TEMPERATURE LIMIT ADJUSTMENT – THE Z82200 FAUCET MAY BE ADJUSTED TO LIMIT THE MAXIMUM OPERATING TEMPERATURE.
 - 3.1. REMOVE CERAMIC MIXING CARTRIDGE (ITEM #4) PER MAINTENANCE INSTRUCTIONS 2.1 THROUGH 2.6 ABOVE.
 - 3.2. REMOVE RED TEMPERATURE LIMIT RING FROM BLUE MIXING CARTRIDGE.
 - 3.3. ROTATE RED TEMPERATURE LIMIT RING CLOCKWISE TO INCREASE MAXIMUM TEMPERATURE OR COUNTER-CLOCKWISE TO DECREASE MAXIMUM TEMPERATURE. RED TEMPERATURE LIMIT RING IS MARKED WITH ARROWS AND +/- TO INDICATE DIRECTION OF ROTATION AND EFFECT ON MAXIMUM TEMPERATURE.
 - 3.4. REPLACE RED TEMPERATURE LIMIT RING IN DESIRED ORIENTATION.
 - 3.5. REINSTALL HANDLE ASSEMBLY BY REVERSING STEPS 2.1 THROUGH 2.5.
 - 3.6. TEST MAXIMUM TEMPERATURE FOR ACCEPTABILITY AND REPEAT STEPS 3.1 THROUGH 3.5 IF NECESSARY.

REPLACEMENT PARTS

G63237	SINGLE CONTROL HANDLE ASSEMBLY
G63241	MOUNTING COMPONENTS FOR SINGLE CONTROL
80242001	CERAMIC MIXING CARTRIDGE
G65506	4" COVER PLATE
G65514	8" COVER PLATE

Trouble Shooting Guide		
Problem	Cause	Solution
FAUCET LEAKS FROM UNDER FAUCET HANDLE ALL SUPPLIES ARE ON.	CARTRIDGE RETAINING NUT TOO LOOSE	REMOVE FAUCET HANDLE. TIGHTEN CARTRIDGE RETAINING NUT. DO NOT OVER TIGHTEN. TIGHTEN UNTIL NUT IS SNUG.
NO WATER COMES OUT OF FAUCET SPOUT. ALL SUPPLIES ARE ON.	AERATOR IS CLOGGED	REMOVE AERATOR. REMOVE DEBRIS AND REINSTALL AERATOR.
WATER DEFLECTS AT AN ANGLE FROM THE FAUCET SPOUT	AERATOR HAS DEBRIS	REMOVE AERATOR. REMOVE DEBRIS AND REINSTALL AERATOR.

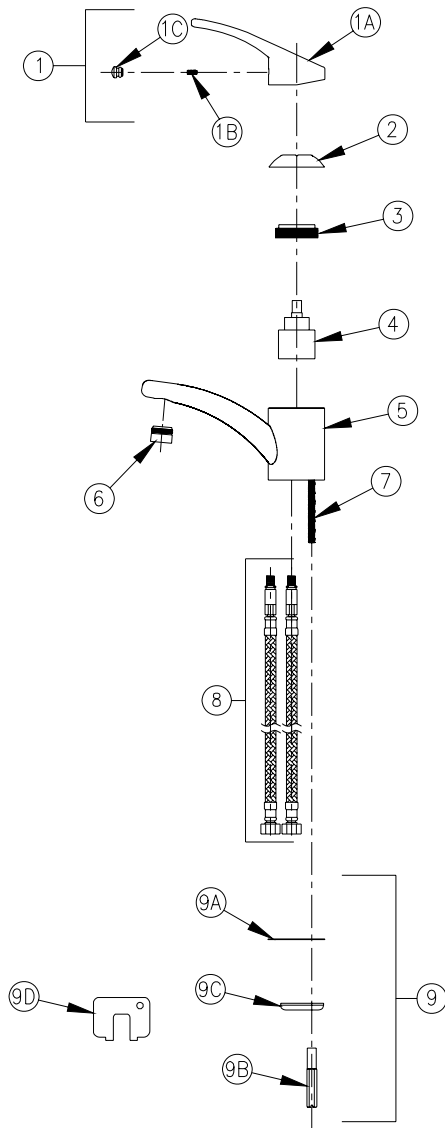

Z82200 PICTURED

Item	Part Number	Description	Qty.
1	G63237	Single Control Handle Assembly	1
1A	63232002	Single Control Handle	1
1B	63234001	1/4-20 x 3/8" Knurled Cup Point Set Screw	1
1C	92255001	Hot/Cold Index Button	1
2	62797001	Domed Cartridge Flange	1
3	62795001	Cartridge Retaining Nut	1
4	80242001	Ceramic Mixing Cartridge	1
5	80110001	5" Single Control Faucet Body w/o Pop-Up Hole	1
6	G63505	Aerator	1
7	63238002	1/4-20 UNC Mounting Stud	1
8	G66621	12" [305mm] S.S. Braided Flex Hoses	1
9	G63241	Mounting Components For Single Control	1
9A	63253001	Gasket	1
9B	63240001	1/4-20 UNC Mounting Nut	1
9C	63239001	Mounting Ring	1
9D	63264004	Domed Cartridge Flange Wrench	1