



Z1012

DEEP SEAL TRAP WITH FLOOR CLEANOUT

SPECIFICATION SHEET

TAG _____

Dimensional Data (inches and [mm]) are Subject to Manufacturing Tolerances and Change Without Notice

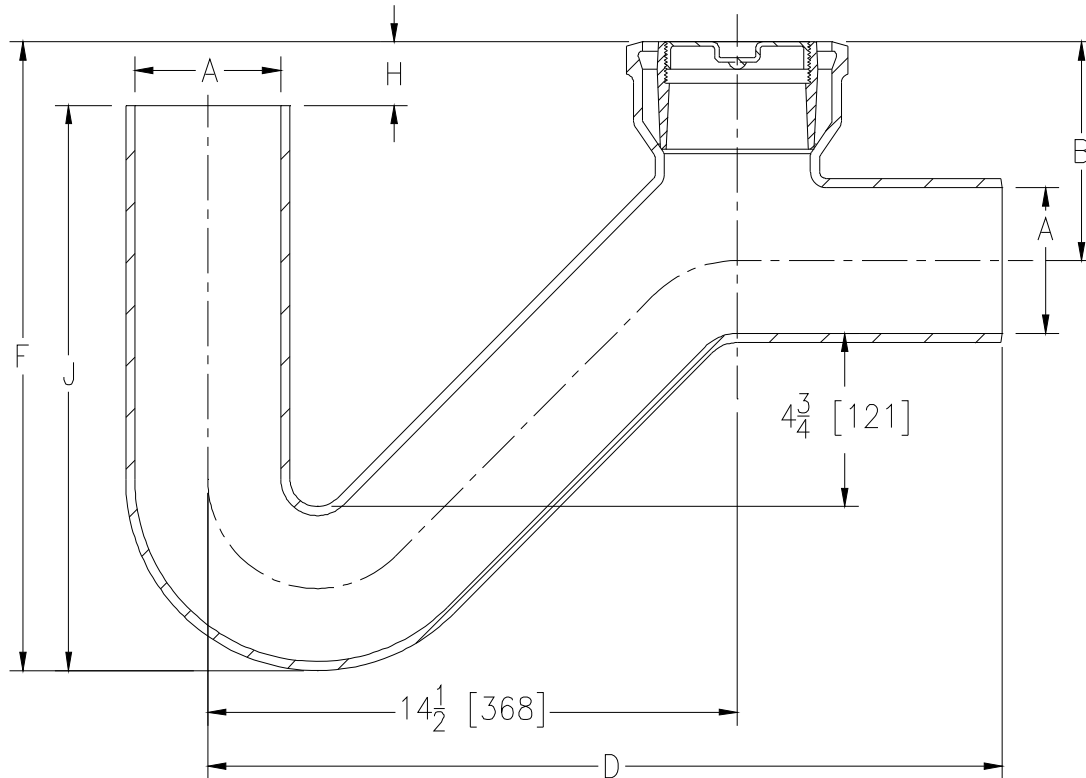

Dimensions in Inches						Approx. Wt. Lb. [kg]
A Pipe Size	B	D	F	H	J	
2 [50]	4-3/4 [121]	16-1/2 [419]	12-3/4 [324]	1/4 [6]	12-1/2 [318]	43 [19]
3 [75]	5-1/2 [140]	21-1/2 [546]	15 [381]	1-1/4 [32]	12-3/4 [324]	45 [20]
4 [100]	6 [152]	21-3/4 [552]	17 [432]	1-3/4 [44]	15-1/2 [394]	47 [21]

ENGINEERING SPECIFICATION:
ZURN Z1012 Deep Seal Trap, Dura-Coated cast iron body for use with bottom outlet drain, with cast iron floor cleanout and plug for caulking into top hub cleanout opening.

CONNECTIONS (Check/specify appropriate options)

PIPE SIZE _____ (Specify size/type) **CONNECTION**

2-4 [50-100] _____ NH No-Hub

PREFIXES

___ Z D.C.C.I. Body*

SUFFIXES

___ -FC Adjustable Floor Cleanout (See Z1406)
 ___ -G Galvanized Cast Iron
 ___ -L (Less) Cleanout Plug

*REGULARLY FURNISHED UNLESS OTHERWISE SPECIFIED

REV. D	DATE: 10/28/10	C.N. NO. 120178
DWG. NO. 58887		PRODUCT NO. Z1012

ZURN INDUSTRIES, LLC. ♦ SPECIFICATION DRAINAGE OPERATION ♦ 1801 Pittsburgh Ave. ♦ Erie, PA 16514

Phone: 814/455-0921 ♦ Fax: 814/454-7929 ♦ World Wide Web: www.zurn.com

In Canada: ZURN INDUSTRIES LIMITED ♦ 3544 Nashua Drive ♦ Mississauga, Ontario L4V1L2 ♦ Phone: 905/405-8272 Fax: 905/405-1292