

Location: _____



C1300-MF

HEAVY DUTY ACCESS HOUSING WITH ANCHOR FLANGES

Specification: MIFAB C1300-MF Series lacquered cast iron heavy duty access housing with fixed anchor flanges, extra heavy duty ductile iron access cover with 6 1/2" (165) clear bottom access.

Function: Access housing for use inside and outside buildings. Flanges are anchored in concrete to keep the housing rigid. Designed to be free of piping so that no loading is transmitted to the plumbing or electrical connections.

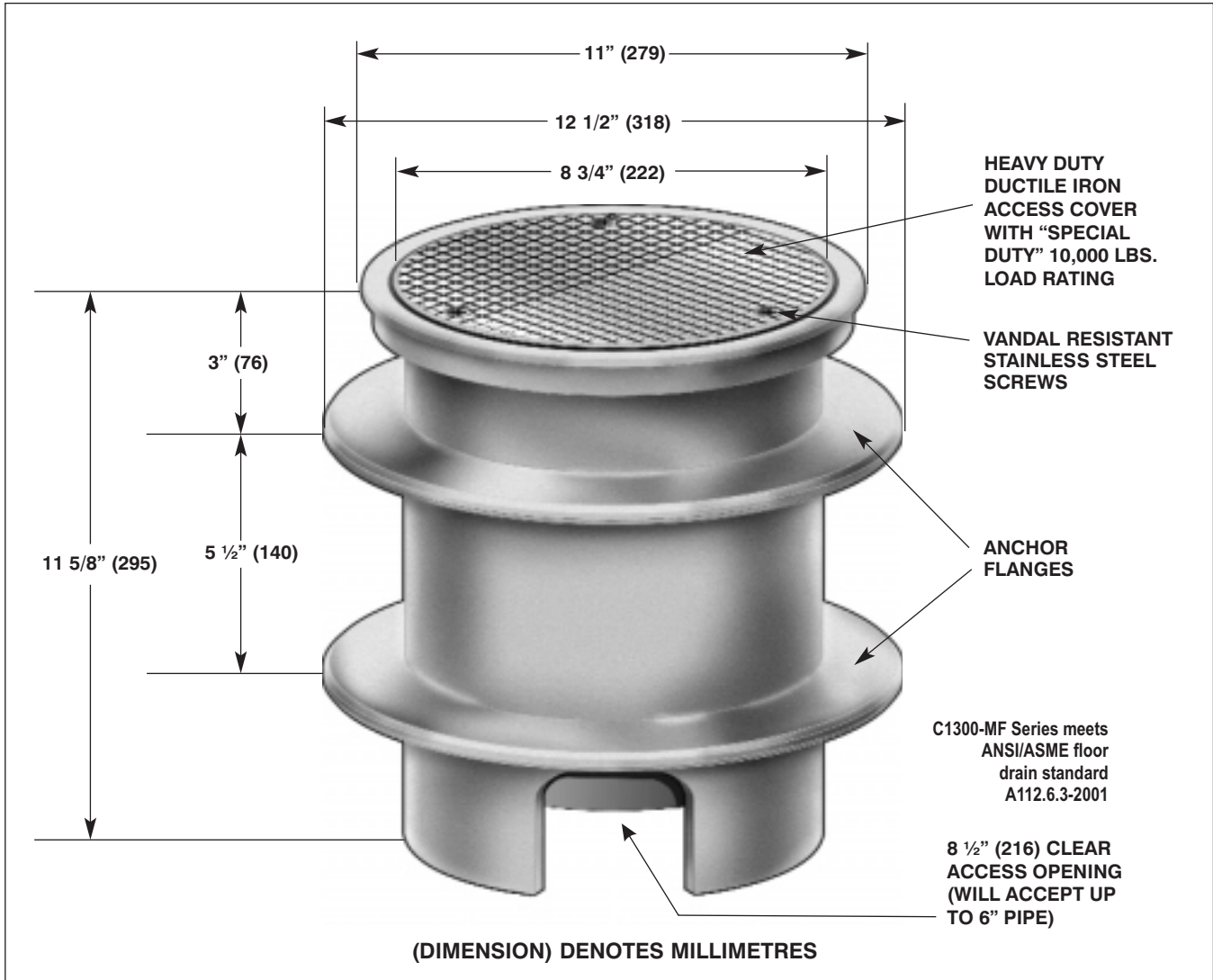

NOTE: IF A CLEANOUT IS REQUIRED, USE MIFAB SERIES C1230 WITH THE C1300-MF

SUFFIX	OPTIONAL VARIATIONS:
-3	Stainless steel cover and frame (vener)
-4	Ductile iron cover
-6	Security screws (TR30 Torx & pin)
-11	Acid resistant epoxy coated body
-13	Galvanized body
-ARRA	ARRA (Stimulus Act) compliant product
-BA	Buy American Act compliant product
-PA	Pennsylvania Steel Act compliant product

Job Name: _____ Page No: _____
 Section No: _____ Contractor: _____
 Schedule No: _____ Purchase Order No: _____