

Thermostatic MIXING VALVES

Hydrotherapy Control Units

Whirlpool Bath
Arm-Leg-Hip-Lower Lumbar Bath

TM-356-____

__TM-356-15 1/2" inlets, 3/4" outlet

TM-356-20 3/4" inlets and outlet *

__TM-356-26 3/4" inlets and outlet *

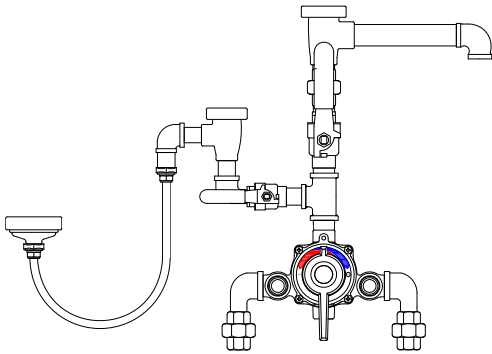
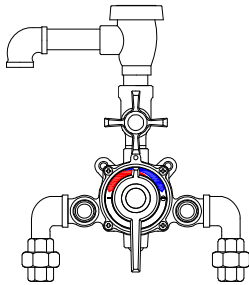

- Thermostatic water mixing valve
- Dura-trol® solid bimetal thermostat directly linked to valve porting to control the intake of hot and cold water and compensate for supply temperature or pressure fluctuations. Dura-trol® is highly responsive and cannot be damaged by extremes in temperature.
- Adjustable high temperature limit stop set for 110°F (43°C)
- Integral checkstops, unions, wall support, cast lever handle
- Outlet volume control / shutoff, vacuum breaker
- Locking Temperature Regulators
- Factory assembled and tested
- Select valve piping finish below
- See Flow Capacity Chart to select correct size

__TM-356-____-W/HA

- Extra 1/2" hose attachment
- Ball valve shutoff
- Vacuum breaker
- 9 feet (2.7m) of 3/8" rubber hose, rose spray, wall hook
- Chrome plated finish only
- Factory assembled and tested

* Valve is ASSE 1017 listed



* Valve is CUPC listed



Engineer's Approval	Job # _____
	Arch/Eng. _____
	Contractor _____

CAUTION! All thermostatic water mixing valves have limitations. They will NOT provide the desired accuracy outside of their flow capacity range. Consult the Flow Capacity Chart and DO NOT OVERSIZE. Minimum flow must be no less than as indicated.

***NOTE:** A limit stop, set for 120°F (49°C), is simply a mechanical setting to prevent excessive handle rotation. If incoming water is hotter than 150°F (65.5°C), the temperature of the factory test, the valve when turned to full HOT may deliver water in excess of 120°F and the limit stop MUST BE RESET BY THE INSTALLER

Note: Leonard Valve Company reserves the right of product, or design modifications without notice or obligation.

OPTIONS:

__SUFFIX RF - Rough bronze finish

__SUFFIX CP - Chrome plated finish

__SUFFIX DT - Dial thermometer



1360 Elmwood Avenue, Cranston, RI 02910 USA

Phone: 401.461.1200 Fax: 401.941.5310

Email: info@leonardvalve.com

Web Site: <http://www.leonardvalve.com>

TM-356-15-20-26

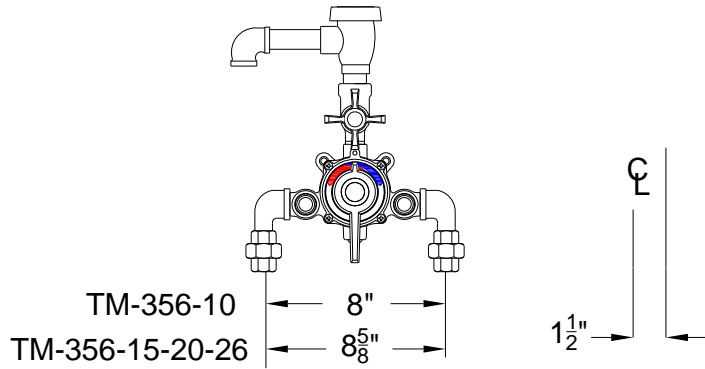

TM-356-15-20-26 W/HA

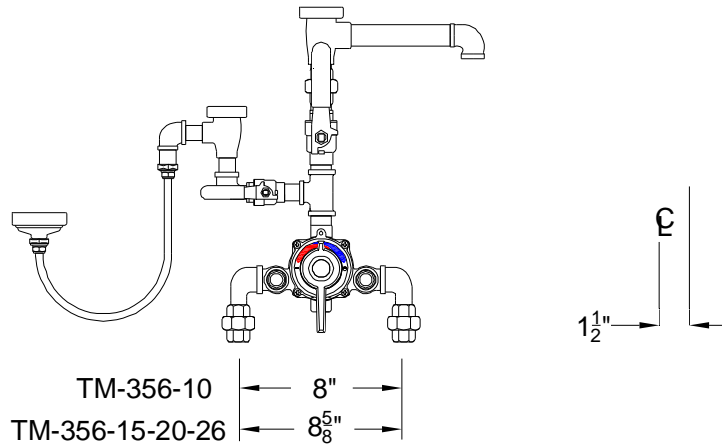

MODEL	IN	OUT	MINIMUM FLOW (GPM) (l/min)	SYSTEM PRESSURE DROP (PSIG)										PSI BAR
				5	10	15	20	25	30	35	40	45	50	
				,3	.7	.97	1.4	1.7	2.1	2.4	2.8	3.1	3.4	
TM-356-15	1/2"	3/4"	1.0 (4.0)	4.5 17	6.0 23	7.0 26	8 30	9 34	9.5 36	10 38	11 42	12 45	13 49	GPM l/min
TM-356-20	3/4"	3/4"	1.0 (4.0)	5 19	6.0 23	7.0 26	8 30	9 34	9.5 36	10 38	11 42	12 45	13 49	GPM l/min
TM-356-26	3/4"	3/4"	1.0 (4.0)	7 26	10 38	13 49	15 57	17 64	19 72	21 80	23 87	25 95	26 98	GPM l/min



1360 Elmwood Avenue, Cranston, RI 02910 USA

Phone: 401.461.1200 Fax: 401.941.5310

Email: info@leonardvalve.com

Web Site: <http://www.leonardvalve.com>