



Z100-EA

SPECIFICATION SHEET

15 [381] DIAMETER MAIN ROOF DRAIN WITH ADJUSTABLE EXTENSION

TAG _____

Dimensional Data (inches and [mm]) are Subject to Manufacturing Tolerances and Change Without Notice

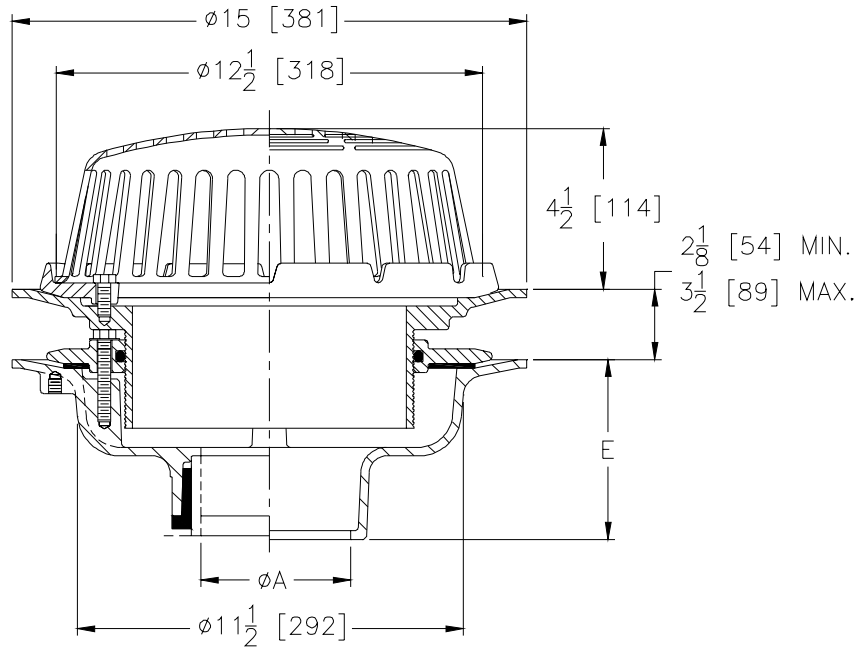

A- Pipe Size In.	Approx. Wt. Lbs. [kg]	Dome Open Area Sq. In. [cm ²]
2-3-4 [51-76-102]	26 [12]	103 [665]
5-6 [127-152]	27 [12]	
8 [203]	28 [13]	

ENGINEERING SPECIFICATION: ZURN Z100-EA

15 [381] Diameter roof drain. Dura-Coated cast iron body with combination membrane flashing clamp/gravel guard adjustable extension, secondary clamping collar with o-ring and low silhouette Poly-Dome strainer.

OPTIONS (Check/specify appropriate options)

PIPE SIZE

- 2 thru 6, 8 [51 thru 152,203]
- 2 thru 6, 8 [51 thru 152,203]
- 2 thru 6, 8 [51 thru 152,203]
- 2,3,4 [51,76,102]

(Specify size/type) OUTLET

- _____ IC Inside Caulk
- _____ IP Threaded
- _____ NH No-Hub
- _____ NL Neo-Loc

E BODY HT. DIM.

- 5 1/4 [133]
- 3 3/4 [95]
- 5 1/4 [133]
- 4 5/8 [117]

PREFIXES

- _____ **Z** D.C.C.I. Body with Poly-Dome*
- _____ **ZA** D.C.C.I. Body with 6 3/4 [171] High Aluminum Dome
- _____ **ZC** D.C.C.I. Body with Cast Iron Dome
- _____ **ZRB** D.C.C.I. Body with Plain Bronze Dome

SUFFIXES

- | | |
|--|--|
| _____ -AC Angular Underdeck Clamp | _____ -SC Secondary Clamping Collar |
| _____ -AR Acid Resistant Epoxy Coated Finish | _____ -SS Stainless Steel Mesh Screen Over Dome |
| _____ -AW 3/4 [19] to 4 [102] Adj. Water Level Regulator | _____ -VP Vandal-Proof Secured Top |
| _____ -BS Bronze Mesh Screen Over Dome | _____ -W2 2 [51] Internal Water Dam |
| _____ -C Underdeck Clamp | _____ -W3 3 [76] Internal Water Dam |
| _____ -DX Dex-o-tex Flange | _____ -W4 4 [102] Internal Water Dam |
| _____ -E Static Extension 1 [25] thru 4 [102] (Specify Ht.) | _____ -XJ Vertical Expansion Joint (See Z190) |
| _____ -ES Static Extension with Secondary Clamp Collar at Body (For clamping at roof drain body.) | _____ -84 Stainless Steel Perforated Gravel Guard |
| _____ -FG Flush Grate | _____ -85 Stainless Steel Perforated Extension |
| _____ -G Galvanized Cast Iron | _____ -89 2 [51] High External Water Dam |
| _____ -GD Galvanized Cast Iron Dome (ZC only) | _____ -90 90° Threaded Side Outlet Body |
| _____ -H High Dome | |
| _____ -R Roof Sump Receiver | |

REV. D DATE: 11/3/05 C.N. NO. 94124

DWG. NO. 56046 PRODUCT NO. Z100-EA

*REGULARLY FURNISHED UNLESS OTHERWISE SPECIFIED

ZURN INDUSTRIES, INC. ♦ SPECIFICATION DRAINAGE OPERATION ♦ 1801 Pittsburgh Ave. ♦ Erie, PA 16514

Phone: 814/455-0921 ♦ Fax: 814/454-7929 ♦ World Wide Web: www.zurn.com

In Canada: ZURN INDUSTRIES LIMITED ♦ 3544 Nashua Drive ♦ Mississauga, Ontario L4V1L2 ♦ Phone: 905/405-8272 Fax: 905/405-1292