



Z104

15 [381] DIAMETER DEEP SUMP ROOF DRAIN W/ LOW SILHOUETTE DOME

SPECIFICATION SHEET

TAG _____

Dimensional Data (inches and [mm]) are Subject to Manufacturing Tolerances and Change Without Notice

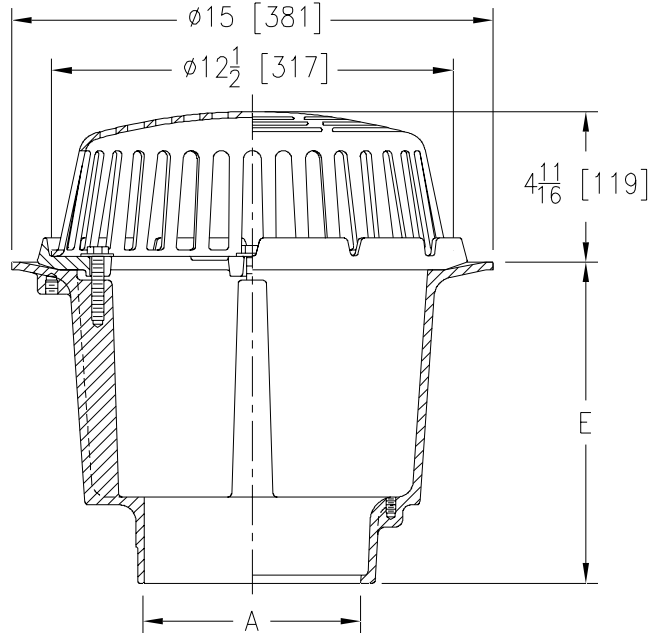

A Pipe Size In.	Approx. Wt. Lbs. [kg]	Dome Open Area Sq. In. [cm ²]
3, 4 [76, 102]	46 [21]	103 [665]
6, 8 [152, 203]		

ENGINEERING SPECIFICATION: ZURN Z104

15 [381] Diameter roof drain. Dura-Coated cast iron deep sump body with combination membrane flashing clamp/gravel guard and low silhouette Poly-Dome.

OPTIONS (Check/specify appropriate options)

PIPE SIZE

- 3, 4, 6 [76, 102, 152]
- 3, 4, 6, 8 [76, 102, 152, 203]
- 3, 4 [76, 102]

(Specify size/type) OUTLET

- ___ IC Inside Caulk
- ___ NH No-Hub
- ___ NL Neo-Loc

'E' BODY HT. DIM.

- 10 [254]
- 10 [254]
- 9 5/16 [237]

PREFIXES

- ___ Z D.C.C.I. Body with Poly-Dome*
- ___ ZA D.C.C.I. Body with 6 3/4 [171] High Aluminum Dome
- ___ ZC D.C.C.I. Body with Cast Iron Dome
- ___ ZRB D.C.C.I. Body with Plain Bronze Dome

SUFFIXES

- | | |
|--|---|
| ___ -AC Angular Underdeck Clamp | ___ -R Roof Sump Receiver |
| ___ -AR Acid Resistant Epoxy Coated Finish | ___ -SC Secondary Clamp Collar |
| ___ -AW 3/4 [19] to 4 [102] Adjustable Water Level Regulator (Specify Ht.) (ZC only) | ___ -SS Stainless Steel Mesh Screen Over Dome |
| ___ -BS Bronze Mesh Screen Over Dome | ___ -VP Vandal-Proof Secured Top |
| ___ -C Underdeck Clamp | ___ -W2 2 [51] Internal Water Dam |
| ___ -DX Dex-o-tex Flange | ___ -W3 3 [76] Internal Water Dam |
| ___ -E Static Extension 1 [25] thru 4 [102] (Specify Ht) | ___ -W4 4 [102] Internal Water Dam |
| ___ -EA Adjustable Extension Assembly 2 1/8 [54] thru 3 1/2 [89] | ___ -84 Stainless Steel Perforated Gravel Guard |
| ___ -FG Flush Grate (Replaces Dome Strainer) | ___ -85 Stainless Steel Perforated Extension |
| ___ -G Galvanized Cast Iron | ___ -89 2 [51] High External Water Dam |
| ___ -GD Galvanized Cast Iron Dome (ZC Only) | |

REV. G	DATE: 9/17/07	C.N. NO. 97338
DWG. NO. 58815	PRODUCT NO. Z104	

*REGULARLY FURNISHED UNLESS OTHERWISE SPECIFIED

ZURN INDUSTRIES, LLC ♦ SPECIFICATION DRAINAGE OPERATION ♦ 1801 Pittsburgh Ave. ♦ Erie, PA 16514

Phone: 814/455-0921 ♦ Fax: 814/454-7929 ♦ World Wide Web: www.zurn.com

In Canada: ZURN INDUSTRIES LIMITED ♦ 3544 Nashua Drive ♦ Mississauga, Ontario L4V1L2 ♦ Phone: 905/405-8272 Fax: 905/405-1292