



Z130

14 9/32 [636] DIAMETER SIPHONIC MAIN ROOF DRAIN EXPLODED PARTS LIST

Dimensional Data (inches and [mm]) are Subject to Manufacturing Tolerances and Change Without Notice

| Item | Name | Part Number | Quan. |
|------|---------------------|--------------|-------|
| 1 | Dome (Z) | 83832-001-60 | 1 |
| 2 | 3/8-16 x 1-1/4 WHCS | 50535-002-50 | 4 |
| 3 | Clamp Collar | 82964-003-78 | 1 |
| 4 | #10-24 x 2-1/2 FHMS | 28100-058-50 | 1 |
| 5 | Grate | 82971-001-18 | 1 |
| 6 | #10-24 x 3/4 FHMS | 28100-021-50 | 2 |
| 7 | Air Baffle | 82970-001-18 | 1 |
| 8 | Body (2NH) | 83031-001-78 | 1 |
| | Body (3NH) | 83031-002-78 | 1 |
| | Body (4NH) | 83031-003-78 | 1 |

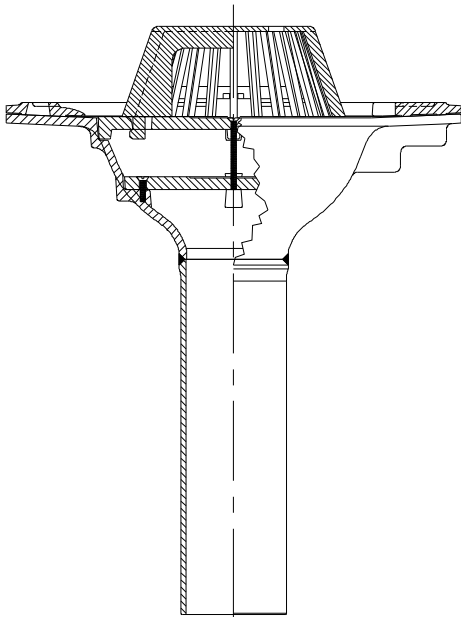
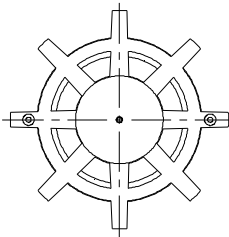
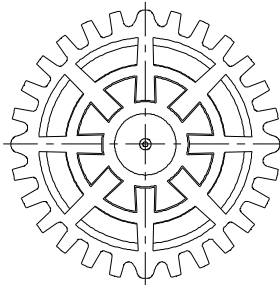
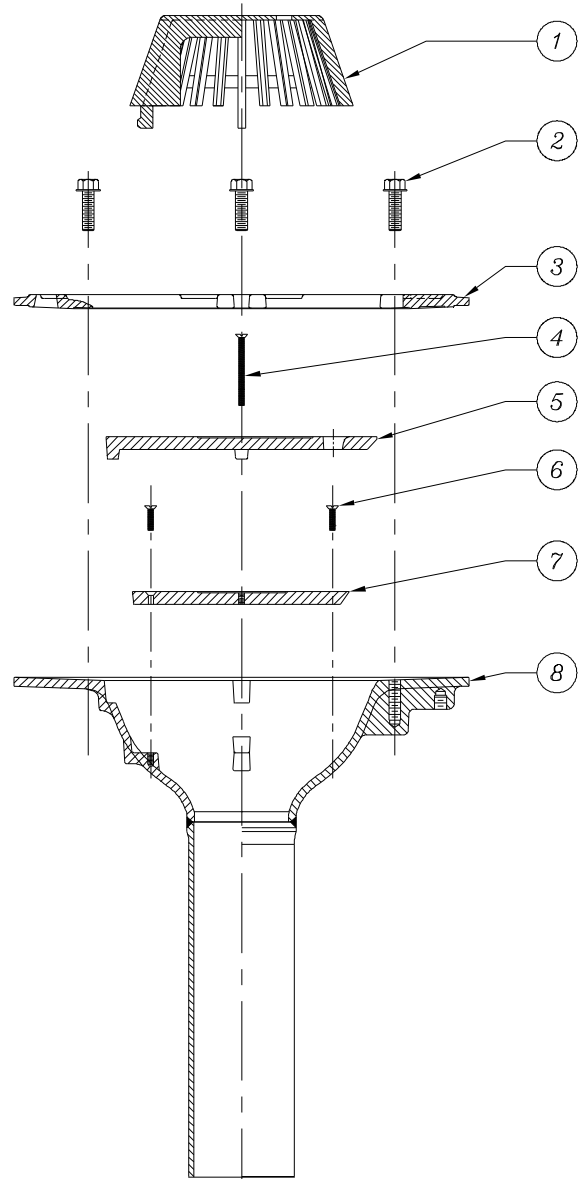
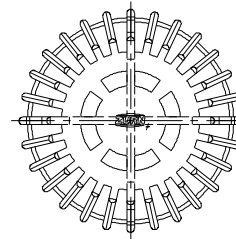

Form # RD78

Date: 10/20/08

C.N. No. 99218

Rev. B

ZURN INDUSTRIES, LLC. ♦ SPECIFICATION DRAINAGE OPERATION ♦ 1801 Pittsburgh Ave. ♦ Erie, PA 16514

Phone: 814/455-0921 ♦ Fax: 814/454-7929 ♦ World Wide Web: www.zurn.com

In Canada: ZURN INDUSTRIES LIMITED ♦ 3544 Nashua Drive ♦ Mississauga, Ontario L4V1L2 ♦ Phone: 905/405-8272 Fax: 905/405-1292