



Z1320

ECOLOTROL CERAMIC DISC WALL HYDRANT Encased, Non-Freeze, Anti-Siphon, Automatic Draining

SPECIFICATION SHEET

TAG _____

Dimensional Data (inches and [mm]) are Subject to Manufacturing Tolerances and Change Without Notice

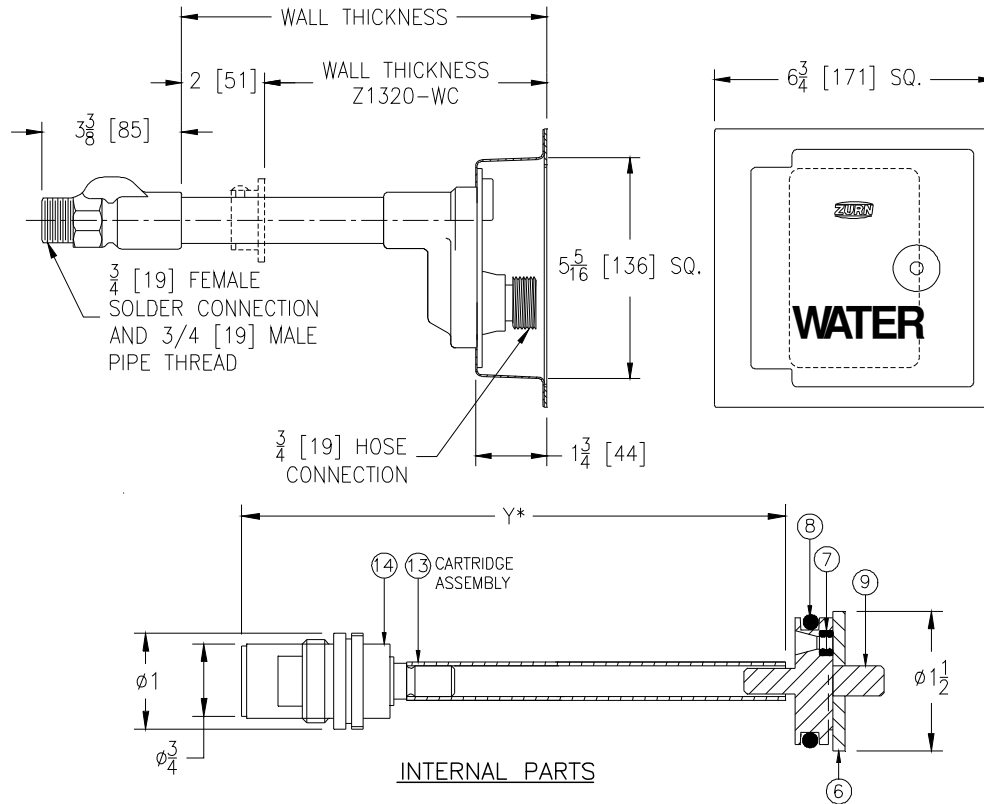

Wall Thickness Inches	Approx. Wt. Lbs. [kg]
6-8 [152-203]	5 [2]
10-12-14 [254-305-356]	6 [3]
16-18 [406-457]	7 [3]
20-22-24 [508-559-610]	8 [4]
26-30 [660-762]	10 [5]

ENGINEERING SPECIFICATION: ZURN Z1320 Encased Ecolotrol "anti-siphon" automatic draining wall hydrant for flush installation. Complete with integral backflow preventer, copper casing, all bronze interior parts with 1/2 turn ceramic disc cartridge and combination 3/4 [19] female solder and 3/4 [19] male pipe thread inlet. Stainless steel box and hinged cover with operating key lock and "WATER" stamped on cover. (All solder connections are lead free.)

Note: During normal operation, the hydrant may take as long as one minute to complete the self-draining process. This drainage feature should not be mistaken for an unsealed shut-off of the hydrant, and over-tightening of the operating coupling is not necessary.

OPTIONS (Check/specify appropriate options)

SUFFIXES

- ___ -CL Cylinder Lock
- ___ -NB Polished Nickel Bronze Face
- ___ -PB Polished Bronze Face
- ___ -RK Hydrant Parts Repair Kit
- ___ -RT12 Ceramic Cartridge Removal Tool (Up to 12 [305] Wall)
- ___ -RT24 Ceramic Cartridge Removal Tool (Up to 24 [610] Wall)
- ___ -RT36 Ceramic Cartridge Removal Tool (Up to 36 [915] Wall)
- ___ -WC Wall Clamp
- ___ -34EL 3/4 [19] IP 90° Solder Inlet Elbow
- ___ -34FIP 3/4 [19] IP Straight Female Inlet Adapter

PARTS LIST

Item	Name	Quan.
14	Cartridge	1
13	Operating Tube	1
9	Operating Coupling	1
8	O' Ring	1
7	O' Ring	2
6	Retaining Washer	1

REV. G DATE: 10/22/10 C.N. NO. 111934

DWG. NO. 58871 PRODUCT NO. Z1320

*WHEN ORDERING REPLACEMENT CARTRIDGE ASSEMBLY SPECIFY Y DIM.

ZURN INDUSTRIES, LLC ♦ SPECIFICATION DRAINAGE OPERATION ♦ 1801 Pittsburgh Ave. ♦ Erie, PA 16514

Phone: 814/455-0921 ♦ Fax: 814/454-7929 ♦ World Wide Web: www.zurn.com

In Canada: ZURN INDUSTRIES LIMITED ♦ 3544 Nashua Drive ♦ Mississauga, Ontario L4V1L2 ♦ Phone: 905/405-8272 Fax: 905/405-1292