

Z1325 WALL HYDRANT Parts Assembly, Parts List, and Operating Rod Assemblies

Z1325 Parts Assembly

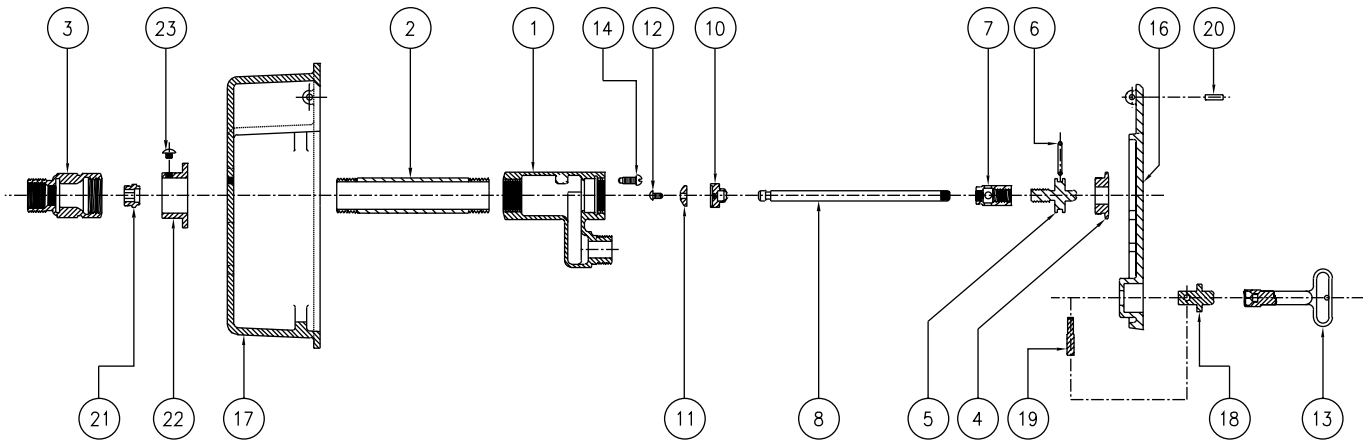

Z1325 Parts List

Item	Description	Qty.	Part No.
1	Head	1	38949-001
2	Casing	2	50270-XXX
3	Valve Housing	2	31258-001
4	Face Nut	2	22156-002
*5	Operating Screw	2	25049-001
*6	O-Ring	2	23750-028
*7	Operating Coupling	2	25147-001
8	Operating Rod	2	45042-XXX
10	Washer Guide	2	25050-001
*11	Washer	2	23075-001
*12	Screw #10-24 NC	2	14853-042
*13	Key	2	59546-001
14	Screw #10-24 NC	1	14853-072
16	Hydrant Cover	1	25511-001
17	Hydrant Body	1	25512-003
18	Locking Pin Mounting	1	25514-002
19	Locking Pin	1	25513-001
20	Hinge Pin	2	45553-010
*21	Removable Seat	2	25262-001
22	Wall Clamp (Optional)	2	50268-001
23	Wall Clamp Screw (Optional)	2	26050-004

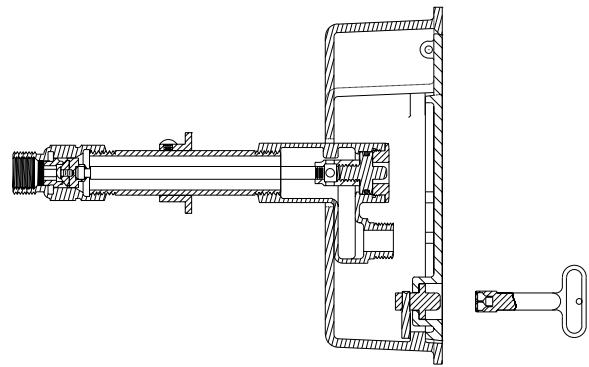

Operating Rod Assemblies

6" Wall	4-3/4"
8" Wall	6-3/4"
10" Wall	8-3/4"
12" Wall	10-3/4"
14" Wall	12-3/4"
16" Wall	14-3/4"
18" Wall	16-3/4"
20" Wall	18-3/4"
22" Wall	20-3/4"
24" Wall	22-3/4"

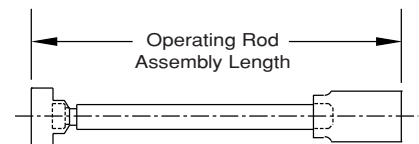

*Items are available in -RK Repair Kit Option bag (#66955-203-9).

Z1325 WALL HYDRANT Troubleshooting Guide

Z1325 Troubleshooting Guide

PROBLEM	CAUSE	SOLUTION
Hydrant will not operate when turning on hot/cold water.	Hot/cold water supply is shut off.	Turn on hot/cold water supply.
Cannot turn the hydrant hot/cold on with key.	Hydrant hasn't been used for a long time – O-Ring has adhered to the operating screw and head.	Follow steps 1-2, 4, and 7-8 of the Service Guide.
Hot/cold water does not shut off completely when hydrant is turned off.	Debris between seat and washer.	Follow steps 1-3 and 6-8 of the Service Guide. Clean by turning water supply on and flush hydrant.
	Washer is worn out.	Follow steps 1-3 and 5-8 of the Service Guide.
	Wire draw in seat.	Replace seat.
Hydrant hot/cold exhibits low flow.	Hot/cold water supply to the hydrant is restricted.	Check hot/cold water supplies to ensure that all upstream valves are fully open.

Z1325 WALL HYDRANT Service Guide

Z1325 Service Guide

Step 1: Shutting Off the Water Supply to the Hydrant

Locate the supply shut-off valve and rotate until water supply is off.

Step 2: Removing the Face Nut and Adjacent Components

Using crescent wrench or 1-1/2 inch open-end wrench, remove the face nut (4) from head (1) by turning counterclockwise.

Step 3: Removing the Internal Operating Assembly

The internal operating assembly (5-8 and 10-12) can be removed by gripping the square end of the operating screw (5) with a pair of pliers and pulling straight out.

If the operating screw O-Ring was not the reason for service – skip to step 5.

Step 4: Replacing the Operating Screw O-Ring

Remove the operating screw (5) from operating coupling (7) by turning clockwise and slip the old O-Ring (6) off, and replace with new O-Ring (6). Reinstall operating screw (5) into operating coupling (7) by turning counterclockwise. **(Note:** Lubricate the operating screw (5) threads and the O-Ring (6) with Lubriplate FGL-2 if needed.)

If the hydrant shutoff washer was not the reason for service – skip to step 8.

Step 5: Replacing the Hydrant Shutoff Washer

Remove #10-24 NC x 3/8 screw (12) using a flat screwdriver and turning screw (12) counterclockwise, remove washer (11) and replace with new washer (11) and new screw (12) turning screw clockwise until tight.

Step 6: Replacing the Internal Operating Assembly

There is a flat or a V-notched boss inside of the hydrant head (1) that keeps the operating coupling (7) from rotating when hydrant is turned on and off. With operating screw (5) turned counterclockwise into operating coupling (7) until it stops, and making sure that a flat side or corner of operating coupling (7) lines up with appropriate boss, reinsert the internal operating assembly into the hydrant.

Step 7: Replacing the Face Nut

Insert face nut (4) into head (1), and rotate clockwise until hand tight, then using a crescent wrench or 1-1/2 inch open end wrench, snug nut (4) tight.

Step 8: Turning On the Water Supply

Locate the water supply shut-off valve and rotate until water supply is on.

Instructions for Usage of 3/4" Adapter Vacuum Breaker (-VB)

The purpose of the adapter vacuum breaker is to provide positive backflow protection of the hydrant and potable water supply to the hydrant. No plumbing changes are required to install the vacuum breaker; it is simply threaded onto the male hose threads on the nozzle portion of the hydrant. To prevent any unauthorized removal or tampering of the vacuum breaker, it is furnished with a break-away head setscrew.

In order to facilitate proper drainage of the hydrant and maintain the non-freeze feature, the vacuum breaker must be manually tripped at the end of

hydrant usage. To do so, first ensure that the hydrant is turned off completely. Remove the hose if one is attached to the hydrant. Gently place pressure on the plastic tip of the vacuum breaker by tilting it to one side and holding in this position. This will allow air to enter the hydrant, and subsequently, allow water to draw out of the hydrant. Once the hydrant has completely drained, release the plastic tip to its original position.

Failure to properly drain the hydrant of water after use may result in freezing of the hydrant and damage to the hydrant components.

Z1325 WALL HYDRANT 3/4" Hose Connection Chart and Graph

Z1325 Wall Hydrant – 3/4" Hose Connection				
Static Pressure (psi)	Running Inlet Pressure (psi)	Running Outlet Pressure (psi)	Flow Rate (gpm)	Pressure Drop Across Unit (psi)
10	4.5	1.8	7.1	2.7
20	12.6	5.4	11.8	7.2
30	20.2	8.9	14.8	11.3
40	28.5	12.6	17.7	15.9
50	36.4	16.2	20.0	20.2
60	43.1	19.3	21.7	23.8
70	55.2	24.7	24.6	30.5
80	62.6	28.0	26.1	34.6
90	69.6	31.2	27.6	38.4

