



# Z1330XL

**ECOLOTRON CERAMIC DISC  
WALL HYDRANT**

**Encased, Anti-Siphon, Automatic Draining, Moderate Climate**

SPECIFICATION SHEET

TAG \_\_\_\_\_

Dimensional Data (inches and [mm]) are Subject to Manufacturing Tolerances and Change Without Notice

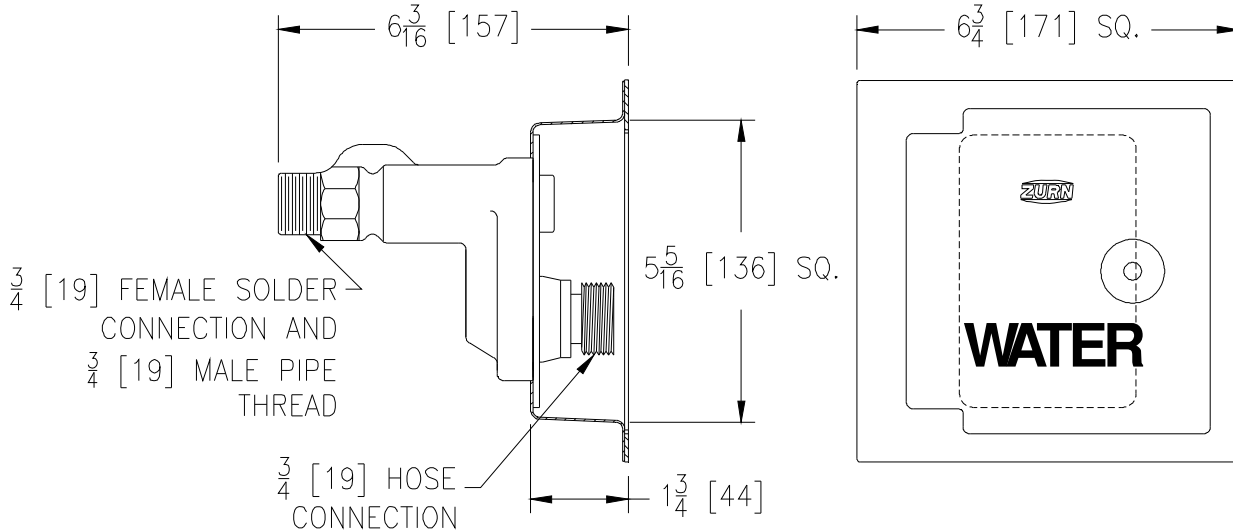

**ENGINEERING SPECIFICATION: ZURN Z1330XL**

Encased, Ecolotrol™, lead-free, anti-siphon, moderate climate / interior wall hydrant for flush installation. Hydrant features integral backflow preventer with anti-siphon technology, all-bronze interior components with 1/2 turn long-life ceramic disc cartridge, combination 3/4" [19] female solder and 3/4" [19] male pipe thread inlet connection, and 3/4" [19] male hose connection. Hydrant furnished with type 304 stainless steel flanged housing with locking hinged cover stamped "WATER" and includes operating key.

*Zurn "XL" Lead-Free compliant products are a line of durable plumbing products designed and manufactured to comply with state laws and local codes that mandate maximum allowable lead content levels. Zurn "XL" products are manufactured in accordance to the Federal SWDA section 1417.*

**OPTIONS** (Check/specify appropriate options)

**SUFFIXES**

- \_\_\_ -CL Cylinder Lock
- \_\_\_ -NB Polished Nickel Bronze Face
- \_\_\_ -PB Polished Bronze Face
- \_\_\_ -RK Hydrant Parts Repair Kit
- \_\_\_ -RT12 Ceramic Cartridge Removal Tool (up to 12 [305] wall)
- \_\_\_ -34EL 3/4 [19] 90° Solder Inlet Elbow
- \_\_\_ -34FIP 3/4 [19] IP Straight Female Inlet Adapter

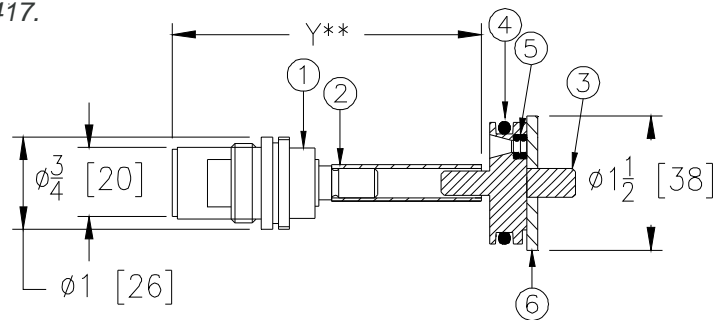

**Internal Components**

Item	Name	Quan.
1	Ceramic Cartridge	1
2	Operating Tube	1
3	Operating Coupling	1
4	O-Ring	1
5	O-Ring	1
6	Retaining Washer	1

\* Regularly furnished unless otherwise specified.

\*\* When ordering replacement cartridge assembly Specify Y dim.