



Z1332XL-EZ

ECOLOTROL CERAMIC DISC WALL HYDRANT Encased, Anti-Siphon, Automatic Draining, Moderate Climate

SPECIFICATION SHEET

TAG _____

Dimensional Data (inches and [mm]) are Subject to Manufacturing Tolerances and Change Without Notice

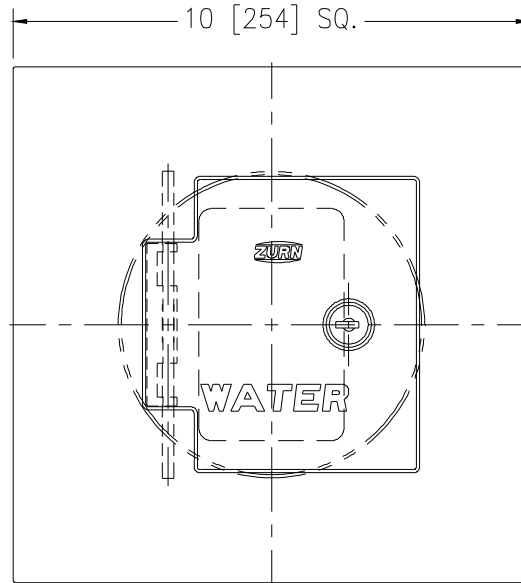
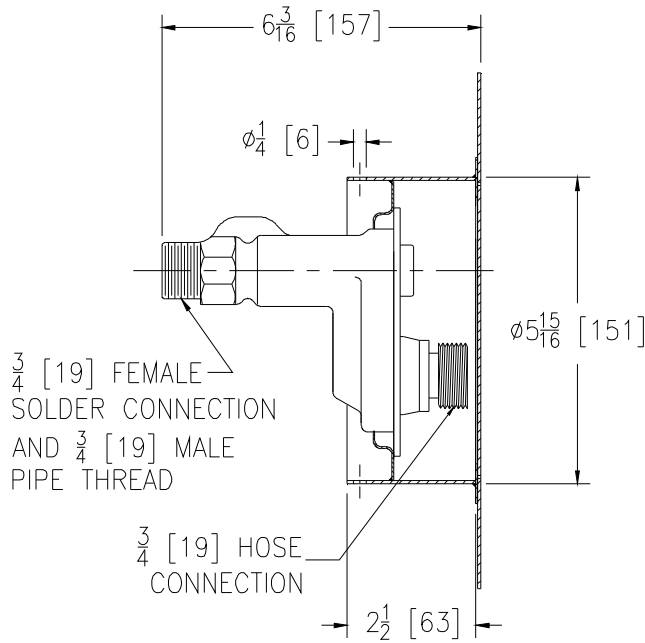

Wall Thickness in [mm]	Approx. Wt. lbs [kg]
8 [203]	4 [2]

ENGINEERING SPECIFICATION: ZURN Z1332XL-EZ

Encased, Ecolotrol™, lead-free, anti-siphon, moderate climate / interior wall hydrant for flush installation in 6" [152] diameter cored hole concrete wall. Hydrant features integral backflow preventer with anti-siphon technology, all-bronze interior components with 1/2 turn long-life ceramic disc cartridge, combination 3/4" [19] female solder and 3/4" [19] male pipe thread inlet connection, and 3/4" [19] male hose connection. Hydrant furnished with type 304 stainless steel housing with large flange and locking hinged cover stamped "WATER" and includes operating key.



PAT. NO. 7,395,834

Zurn "XL" Lead-Free compliant products are a line of durable plumbing products designed and manufactured to comply with state laws and local codes that mandate maximum allowable lead content levels. Zurn "XL" products are manufactured in accordance to the Federal SWDA section 1417.

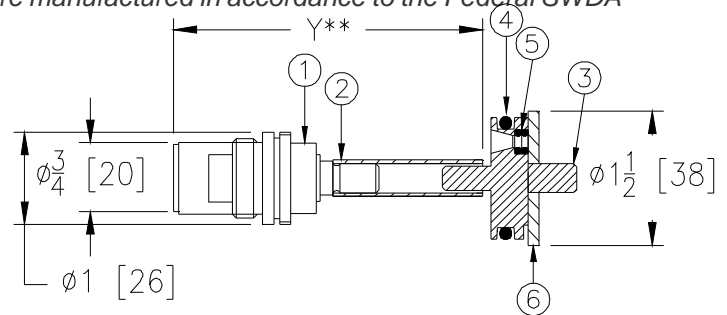

OPTIONS (Check/specify appropriate options)

SUFFIXES

- ___ -CL Cylinder Lock
- ___ -RK Hydrant Parts Repair Kit
- ___ -RT12 Ceramic Cartridge Removal Tool (up to 12 [305] wall)
- ___ -34EL 3/4 [19] 90° Solder Inlet Elbow
- ___ -34FIP 3/4 [19] IP Straight Female Inlet Adapter
- ___ -8 8 [203] Diameter Cored Hole

Internal Components

Item	Name	Quan.
1	Ceramic Cartridge	1
2	Operating Tube	1
3	Operating Coupling	1
4	O-Ring	1
5	O-Ring	1
6	Retaining Washer	1

* Regularly furnished unless otherwise specified.

** When ordering replacement cartridge assembly Specify Y dim.