



Z1390 POST HYDRANT Exposed Head, Non-Freeze

SPECIFICATION SHEET

TAG _____

Dimensional Data (inches and [mm]) are Subject to Manufacturing Tolerances and Change Without Notice

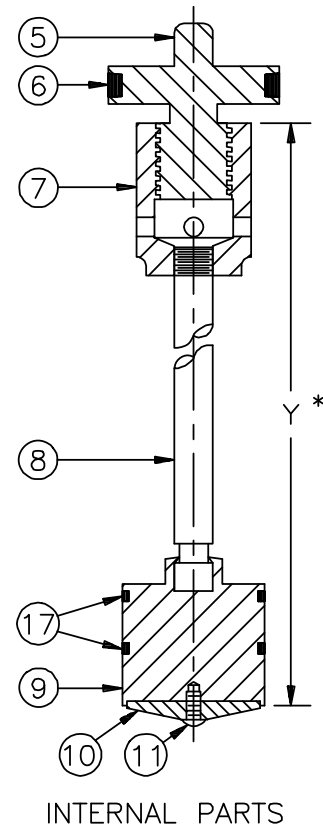
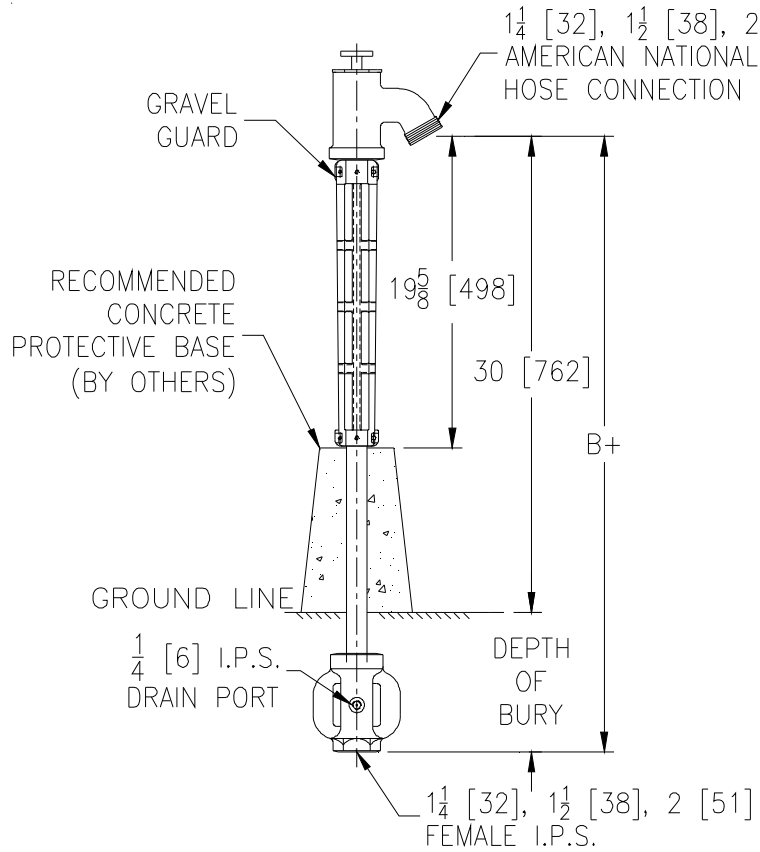

Depth of Bury Feet	B+ Dim. Feet	Approx. Wt. Lbs. [kg]
2 [610]	4 1/2 [1372]	57 [26]
3 [914]	5 1/2 [1676]	62 [28]
4 [1219]	6 1/2 [1981]	67 [30]
5 [1524]	7 1/2 [2286]	72 [33]
6 [1829]	8 1/2 [2591]	77 [35]
7 [2134]	9 1/2 [2896]	82 [37]
8 [2438]	10 1/2 [3200]	87 [39]
9 [2743]	11 1/2 [3505]	92 [42]
10 [3048]	12 1/2 [3810]	97 [44]

ENGINEERING SPECIFICATION: ZURN Z1390 Exposed, non-freeze post hydrant. Complete with galvanized steel casing and cast aluminum casing guard, all bronze interior parts, bronze seat and replaceable seat washer, and non-turning operating rod with free-floating compression closure valve with 1-1/4 [32], 1-1/2 [38] or 2 [51] connection. "T" handle operating key included. Hydrant is equipped with a tapped 1/4 [19] drain port in valve housing.

Note:

1. 'B' dim. based on outlet connection 30 [762] above ground.
2. IMPORTANT Hydrant must be opened one turn minimum to seal drain port during use.

CONNECTION TYPE:

- _____ 1-1/4 [32] Hose Connection
- _____ 1-1/2 [38] Hose Connection
- _____ 2 [51] Hose Connection

PARTS LIST

Item	Name	Quan.
5	Operating Screw	1
6	O-Ring	1
7	Operating Coupling	1
8	Operating Rod	1
9	Washer Guide	1
10	Washer (neoprene)	1
11	Screw	1
17	O-Ring	2

OPTIONS (Check/specify appropriate options)

SUFFIXES

- _____ -BC Bronze Casing
- _____ -RK Hydrant Parts Repair Kit
- _____ -WH Wheel Handle

REV. G	DATE: 10/22/10	C.N. NO. 111952
DWG. NO. 58883	PRODUCT NO. Z1390	

*WHEN ORDERING REPLACEMENT PARTS SPECIFY Y DIM.