

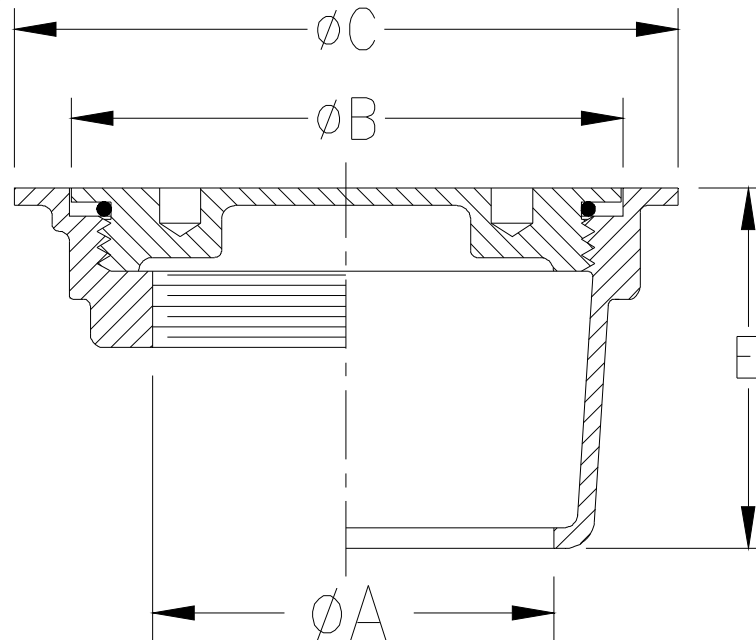

Z1456 DECK CLEANOUT

TAG _____

Dimensional Data (inches and [mm]) are Subject to Manufacturing Tolerances and Change Without Notice



A Pipe Size	Dimensions In Inches				Approx. Wt. Lbs. [kg]
	IC		IP		
	B	C	B	C	
2 [51]	3-1/2 [89]	4-3/4 [121]	2-3/4 [70]	4 [102]	3 [1]
3 [76]	5 [127]	6 [152]	3-1/2 [89]	4-7/8 [124]	4 [2]
4 [102]	6 [152]	7-3/8 [187]	4-1/2 [114]	6 [152]	6 [3]
5 [127]	8 [203]	9-3/8 [238]	7-7/8 [200]	9-3/8 [238]	10 [5]
6 [152]	8 [203]	9-3/8 [238]	7-7/8 [200]	9-3/8 [238]	12 [5]
8 [203]	-	-	9-7/8 [251]	11 [279]	16 [7]

ENGINEERING SPECIFICATION:

ZURNZANB1456
Deck cleanout, nickel bronze body with scoriated deck plug and O-ring seal.

OPTIONS (Check/specify appropriate options)

PIPE SIZE

- 2 [51]
- 3, 4 [76, 102]
- 5, 6 [127, 152]
- 2, 3, 4 [51, 76, 102]
- 5, 6 [127, 152]
- 8 [203]

(Specify size/type) **OUTLET**

- _____ IC Inside Caulk
- _____ IC Inside Caulk
- _____ IC Inside Caulk
- _____ IP Threaded
- _____ IP Threaded
- _____ IP Threaded

'E' BODY HT. DIM.

- 3-1/8 [80]
- 3-1/4 [83]
- 3-1/2 [89]
- 1-1/2 [38]
- 1-5/8 [41]
- 2 [51]

PREFIXES

- _____ ZAB Bronze with Polished Scoriated Top
- _____ ZANB Nickel Bronze with Polished Scoriated Top*

SUFFIXES

- _____ -DX Dex-o-Tex Flange (3 [76] and 4 [102] Only)
- _____ -SW Extra Spanner Wrench

REV. D	DATE: 9/21/09	C.N. NO. 110231
DWG. NO. 58773	PRODUCT NO. Z1456	

*REGULARLY FURNISHED UNLESS OTHERWISE SPECIFIED