



Z1472 AIR INLET

SPECIFICATION SHEET

TAG _____

Dimensional Data (inches and [mm]) are Subject to Manufacturing Tolerances and Change Without Notice

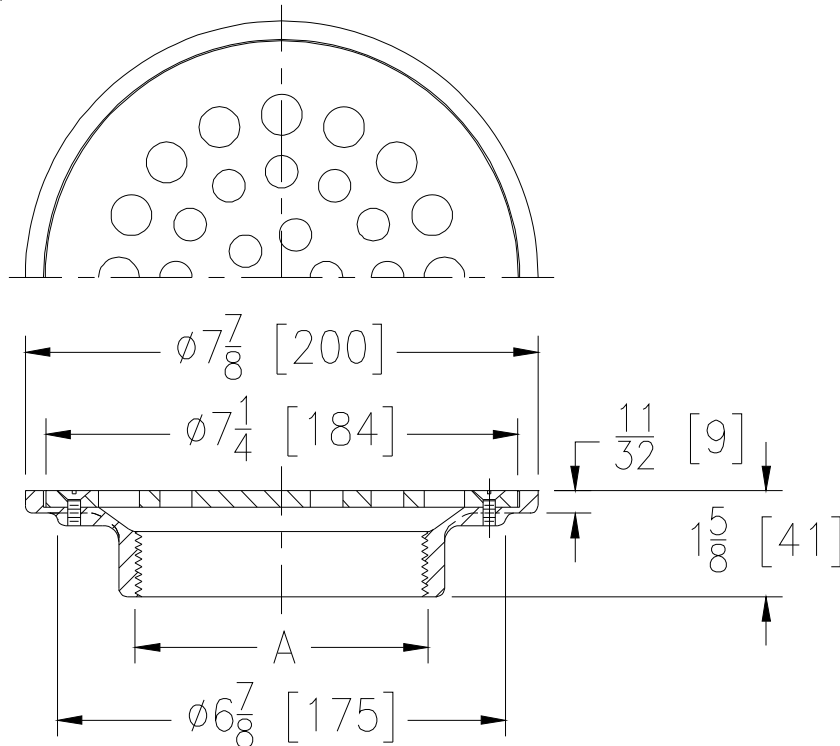

A Pipe Size Inches	Approx. Wt. Lbs [kg]
4 [102]	6 [3]

ENGINEERING SPECIFICATION: ZURNZANB1472

Fresh Air Inlet. Round, nickel bronze with secured cover and female threaded connection.

OPTIONS (Check/specify appropriate options)

PIPE SIZE

4 [102]

OUTLET

_____ IP Threaded

PREFIXES

- _____ ZAB Bronze with Polished Cover
- _____ ZANB Nickel Bronze with Polished Cover*

SUFFIXES

- _____ -CP Chrome Plated
- _____ -VP Vandal-Proof Screws

REV. D	DATE: 11/8/10	C.N. NO. 120270
DWG. NO. 58785		PRODUCT NO. Z1472

*REGULARLY FURNISHED UNLESS OTHERWISE SPECIFIED