



Z150
**14 [356] SQUARE TOP PROM-DECK DRAIN W/
 HEEL-PROOF GRATE & ROTATABLE FRAME**

SPECIFICATION SHEET

TAG _____

Dimensional Data (inches and [mm]) are Subject to Manufacturing Tolerances and Changes Without Notice

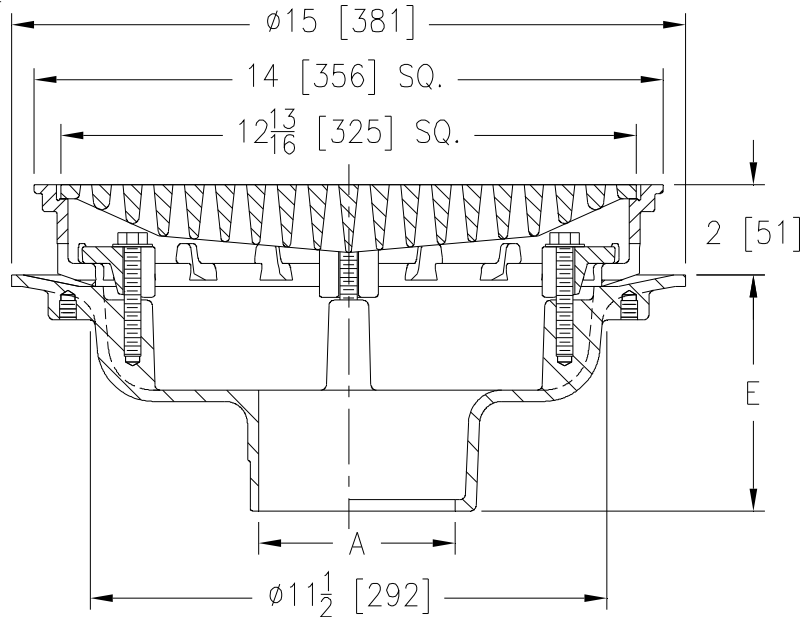

A- Pipe Size In.	Approx. Wt. Lbs. [kg]	Grate Open Area Sq. In. [cm ²]
2-3-4 [51-76-102]	53 [24]	44 [284]
5-6 [127-152]		
8 [203]	54 [24]	

ENGINEERING SPECIFICATION: ZURN Z150
 14 [356] Square Top Prom-Deck drain. Dura-Coated cast iron body with rotatable square promenade frame with seepage openings, frame clamps and heavy-duty heel-proof grate.

OPTIONS (Check/specify appropriate options)

PIPE SIZE

- 2 thru 6-8 [51 thru 152-203]
- 2 thru 6-8 [51 thru 152-203]
- 2 thru 6,8 [51 thru 152-203]
- 2-3-4 [51-76-102]

(Specify size/type) **OUTLET**

- ___ IC Inside Caulk
- ___ IP Threaded
- ___ NH No-Hub
- ___ NL Neo-Loc

E BODY HT. DIM.

- 5-1/4 [133]
- 3-3/4 [95]
- 5-1/4 [133]
- 4-9/16 [116]

PREFIXES

- ___ Z D.C.C.I. Body with Top*
- ___ ZB D.C.C.I. Body with Polished Bronze Top (Add 3/16 [5] to 2 [51] Dim & 3/8 [10] to 14 [356] Dim.)
- ___ ZN D.C.C.I. Body with Polished Nickel Bronze Top (Add 3/16 [5] to 2 [51] Dim. & 3/8 [10] to 14 [356] Dim.)

SUFFIXES

- ___ -AR Acid Resistant Epoxy Coated
- ___ -C Underdeck Clamp
- ___ -DB Deep Sump Body
- ___ -DE Deck Extension
- ___ -DG Duresist Grate
- ___ -DP Top-Set[®] Roof Deck Plate (Replaces both the -C and -R)
- ___ -DR Top-Set[®] Drain Riser (Adjustment from 3-5/8 [92] to 7-1/4 [184])
- ___ -DT Decorative Polished Top (ZB and ZN Only)
- ___ -DX Dex-o-tex Flange (ZB and ZN Only)
- ___ -E Static Extension 1 [25] thru 4 [102] (Specify Ht.)
- ___ -EA Adjustable Extension Assembly 2-1/8 [54] thru 3-1/2 [89]
- ___ -EB Top-Set[®] Adjustable Extension Assembly
- ___ -G Galvanized Cast Iron
- ___ -HF High Flow Ductile Iron Grate (Open Area = 61 in² [394 cm²])
- ___ -R Roof Sump Receiver
- ___ -S Secondary Strainer
- ___ -SC Secondary Clamp Collar
- ___ -TC Neo-Loc Test Cap Gasket (2 [51] - 4 [102] NL Bottom Outlet Only)
- ___ -TS Top Secured with Slotted Screws
- ___ -VP Vandal-Proof Secured Top
- ___ -XJ Vertical Expansion Joint (See Z190)
- ___ -Y Sediment Bucket
- ___ -85 Stainless Steel Perforated Extension
- ___ -90 90° Threaded Side Outlet Body (2 [51] thru 6 [152])

*REGULARLY FURNISHED UNLESS OTHERWISE SPECIFIED

REV. F	DATE: 10/20/10	C.N.NO. 111892
DWG. NO. 67679	PRODUCT NO. Z150	