



Z158

SPECIFICATION SHEET

10 [254] SQUARE TOP PROM-DECK DRAIN W/ HEEL-PROOF GRATE & ROTATABLE FRAME

TAG _____

Dimensional Data (inches and [mm]) are Subject to Manufacturing Tolerances and Changes Without Notice

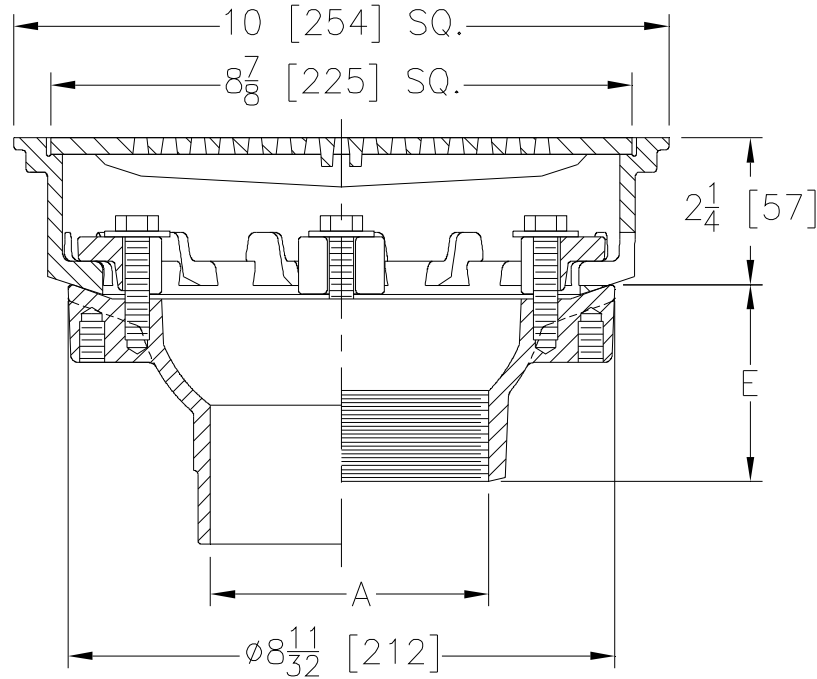

A Pipe Size In.	Approx. Wt. Lbs. [kg]	Grate Open Area Sq. In. [cm ²]
2-3-4 [51-76-102]	20 [9]	21 [136]

ENGINEERING SPECIFICATION: ZURN Z158

10 [254] Square Top Prom-Deck drain, Dura-Coated cast iron body with rotatable square promenade frame with seepage openings, frame clamps and light duty heel-proof grate.

OPTIONS (Check/specify appropriate options)

PIPE SIZE

- 2-3-4 [51-76-102]
- 4 [102]
- 3 [76]
- 2 [51]
- 2-3-4 [51-76-102]
- 2-3-4 [51-76-102]

(Specify size/type) OUTLET

- ___ IC Inside Caulk
- ___ IP Threaded
- ___ IP Threaded
- ___ IP Threaded
- ___ NH No-Hub
- ___ NL Neo-Loc

'E' BODY HT. DIM.

- 3-7/8 [98]
- 3 [76]
- 2-3/4 [70]
- 2-7/16 [62]
- 4 [102]
- 3-13/16 [97]

PREFIXES

- ___ Z D.C.C.I. Body with Top*
- ___ ZB D.C.C.I. Body with Polished Bronze Top (Add 3/16 [5] to 2-1/4 [57] Dim & 5/8 [16] to 10 [254] Dim.)
- ___ ZN D.C.C.I. Body with Polished Nickel Bronze Top (Add 3/16 [5] to 2-1/4 [57] Dim & 5/8 [16] to 10 [254] Dim.)

SUFFIXES

- ___ -AR Acid Resistant Epoxy Coated Finish
- ___ -C Underdeck Clamp
- ___ -DG Duresist Grate
- ___ -DP Top-Set® Roof Deck Plate (Replaces Both the -C and -R)
- ___ -E 2 [51] High Static Extension
- ___ -EB Top-Set® Adjustable Extension Assembly
- ___ -G Galvanized Cast Iron
- ___ -R Roof Sump Receiver
- ___ -SC Secondary Clamp Collar
- ___ -TC Neo-Loc Test Cap Gasket (2[51] - 4[102] NL Bottom Outlet only)
- ___ -TS Top Secured with Slotted Screws
- ___ -VP Vandal-Proof Secured Top
- ___ -XJ Vertical Expansion Joint (See Z190)
- ___ -Y Sediment Bucket
- ___ -85 Stainless Steel Perforated Extension
- ___ -90 90° Threaded Side Outlet Body (2 [51] thru 4 [102])

Note: -DP and -90 option can not be specified together.

REV. K DATE: 08/13/13 C.N. NO. 129781

PROD./DWG. NO. Z158

*REGULARLY FURNISHED UNLESS OTHERWISE SPECIFIED

ZURN INDUSTRIES, LLC ♦ SPECIFICATION DRAINAGE OPERATION ♦ 1801 Pittsburgh Ave. ♦ Erie, PA 16514

Phone: 814455-0921 ♦ Fax: 814454-7929 ♦ World Wide Web: www.zurn.com

In Canada: ZURN INDUSTRIES LIMITED ♦ 3544 Nashua Drive ♦ Mississauga, Ontario L4V1L2 ♦ Phone: 905405-8272 Fax: 905405-1292