



Z1737

15 [381] DIAMETER FLOOR DRAIN

SPECIFICATION SHEET

TAG _____

Dimensional Data (inches and [mm]) are Subject to Manufacturing Tolerances and Change Without Notice

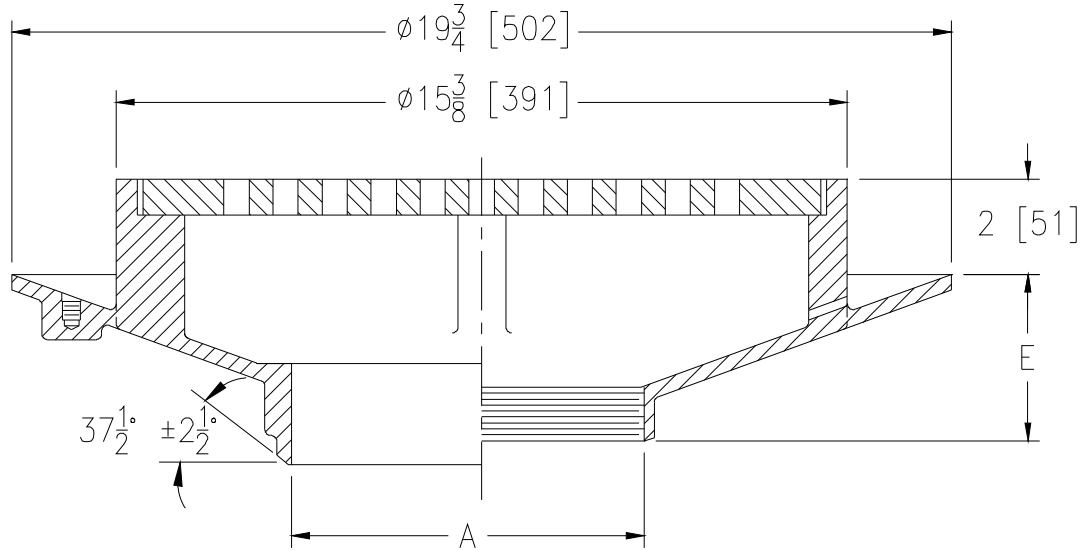

| A- Pipe Size In. | Approx. Wt. Lbs. [kg]. | Grate Open Area Sq. In. [cm ²] |
|------------------|------------------------|--|
| 8 [203] | 85 [39] | 55 [355] |

ENGINEERING SPECIFICATION: ZURNZ1737
 15 [381] Diameter extra heavy duty floor drain, All Type 304 (CF8) stainless steel body with integral anchor flange, and non-tilt grate with plain finish.

OPTIONS (Check/specify appropriate options)

| PIPE SIZE | (Specify size/type) | OUTLET | 'E' BODY HT. DIM. |
|-----------|---------------------|---|-------------------|
| 8 [203] | _____ | BW Butt-weld (Specify Schedule 10, 40 or 80) | 6 [152] |
| 8 [203] | _____ | IP Threaded | 5-1/2 [140] |

PREFIXES

- _____ Z Type 304 (CF8) Stainless Steel Body*
- _____ ZM Type 316 (CF8M) Stainless Steel Body

SUFFIXES

- _____ -K Seepage Holes Only
- _____ -KC Clamp Collar with Seepage Holes
- _____ -SF Satin Finish Top
- _____ -TS Top Secured with Slotted Screws
- _____ -VP Vandal-Proof Secured Top

| | | |
|----------------|----------------|-------------------|
| REV. D | DATE: 11/18/10 | C.N. NO. 120397 |
| DWG. NO. 59300 | | PRODUCT NO. Z1737 |

*REGULARLY FURNISHED UNLESS OTHERWISE SPECIFIED