



Z1749

**12 X 12 [305 x 305] SANI-FLOR RECEPTOR
4 [102] SUMP DEPTH**

SPECIFICATION SHEET

TAG _____

Dimensional Data (inches and [mm]) are Subject to Manufacturing Tolerances and Change Without Notice

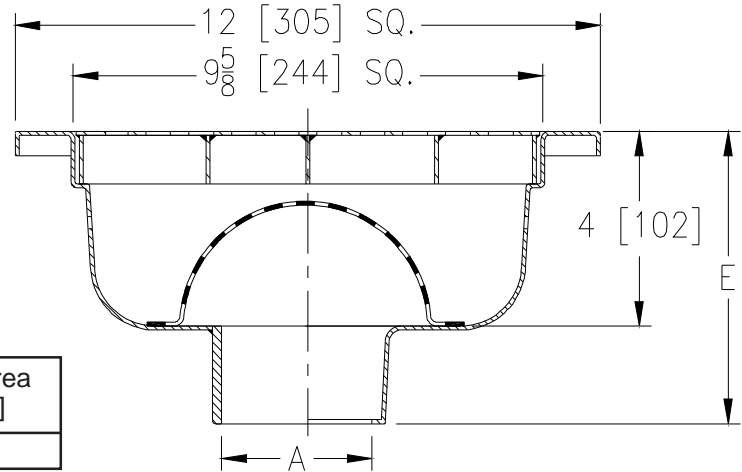

A- Pipe Size In.	Approx. Wt. Lbs. [kg]	Grate Open Area Sq. In. [cm ²]
2-3-4 [51-76-102]	15 [7]	23 [148]

Engineering Specification: ZURN Z1749

12 x 12 x 4 [305 x 305 x 102] deep, 16 gage, All Type 304 (CF8) Stainless Steel light-duty Sani-Flor receptor with non-tilt, loose set full grate with 1/2 [13] square openings and anti-splash stainless steel interior dome strainer.

Options (Check/specify appropriate options)

Pipe Size (ØA)

- 2 thru 4 [51 thru 102]
- 2 [51]
- 3 [76]
- 4 [102]
- 2 thru 4 [51 thru 102]
- 2 thru 4 [51 thru 102]

(Specify size/type) **OUTLET**

- ___ IC Inside Caulk
- ___ IP Threaded
- ___ IP Threaded
- ___ IP Threaded
- ___ NH No-Hub
- ___ NL Neo-Loc

'E' BODY HT. DIM.

- 6-9/16 [167]
- 5-5/16 [134]
- 5-9/16 [141]
- 6-1/16 [154]
- 6-1/16 [154]
- 5-13/16 [148]

Prefixes

- ___ Z Type 304 (CF8) Stainless Steel Body*
- ___ ZM Type 316 (CF8M) Stainless Steel

Suffixes

- | | |
|---|--|
| ___ -DX Dex-o-tex Flange | ___ -1 (Less) Grate |
| ___ -HD Extra Heavy Duty Top Frame & Grate | ___ -2 1/2 Grate |
| ___ -HP Heel-Proof Grate | ___ -3 3/4 Grate |
| ___ -K Anchor Flange (May not be used w/ -P) | ___ -4 Full Grate w/ 3 [76] Square Opening |
| ___ -KC Anchor Flange w/ Seepage Holes and Clamp Collar (May not be used w/ -P) | ___ -5 Grate w/ 4 [102] dia. x 3-3/4 [95] High Funnel |
| ___ -LSH (Less) Seepage Holes | ___ -8 Grate w/ 8-3/8 x 3-5/8 x 3-3/4 [213 x 92 x 95] High Oval Funnel |
| ___ -P 1/2 [13] Trap Primer Connection (May not be used w/ -K or -KC) | ___ -15 Solid Cover |
| ___ -SG Solid Gasketed Cover | ___ -16 1/2 Solid Cover |
| ___ -TC Neo-Loc Test Cap Gasket (2 - 4 [51-102] NL Bottom Outlet Only) | ___ -17 3/4 Solid Cover |
| ___ -VP Vandal-Proof Secured Top | ___ -18 Solid Cover w/ 3 [76] Square Center Opening |
| ___ -Y Sediment Bucket | ___ -19 Full Hinged Grate |
| ___ -YS Suspended Sediment Bucket | ___ -20 Full Hinged Cover |

* Regularly furnished unless otherwise specified.