



Z1752

12 X 12 [305 X 305] SANI-FLOR RECEPTOR 10 [254] SUMP DEPTH

SPECIFICATION SHEET

TAG _____

Dimensional Data (inches and [mm]) are Subject to Manufacturing Tolerances and Change Without Notice

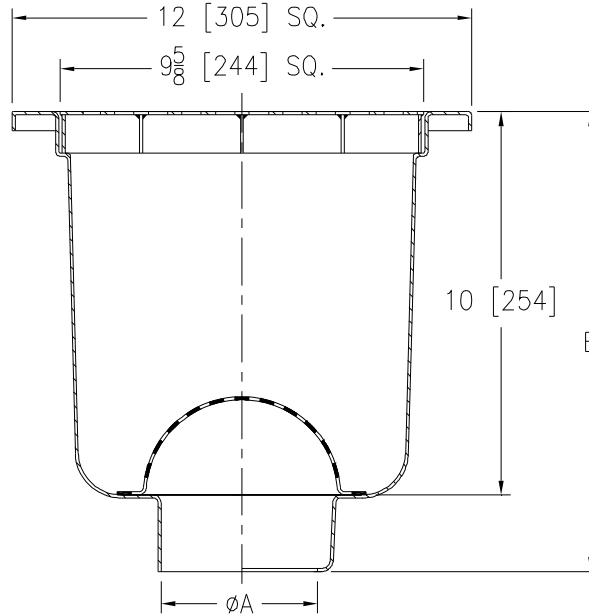

A- Pipe Size In.	Approx. Wt. Lbs. [kg]	Grate Open Area Sq. In. [cm ²]
2-3-4 [51-76-102]	22 [10]	23 [148]
6 [152]	23 [10]	23 [148]

ENGINEERING SPECIFICATION: ZURN Z1752

12 x 12 x 10 [305 x 305 x 254] deep, 16 gage, All Type 304 (CF8) Stainless Steel light-duty Sani-Flor receptor with non-tilt, loose set full grate with 1/2 [13] square openings and anti-splash stainless steel interior dome strainer.

OPTIONS (Check/specify appropriate options)

PIPE SIZE

2 thru 4 [51 thru 102]
2 [51]
3 [76]
4 [102]
2 thru 4, 6 [51 thru 102, 152]
2 thru 4 [51 thru 102]

(Specify size/type) OUTLET

_____ IC Inside Caulk
_____ IP Threaded
_____ IP Threaded
_____ IP Threaded
_____ NH No-Hub
_____ NL Neo-Loc

'E' BODY HT. DIM.

12-9/16 [319]
11-5/16 [287]
11-9/16 [294]
12-1/16 [306]
12-1/16 [306]
11-13/16 [300]

PREFIXES

_____ Z Type 304 (CF8) Stainless Steel Body*
_____ ZM Type 316 (CF8M) Stainless Steel

SUFFIXES

_____ -DX	Dex-o-tex Flange	_____ -3	3/4 Grate
_____ -HD	Extra Heavy-Duty Grate	_____ -4	Full Grate w/ 3 [76] Square Center Opening
_____ -HP	Heel-Proof Grate	_____ -5	Grate w/ 4 [102] Dia. x 3-3/4 [95] High Type 304 Stainless Steel Funnel
_____ -K	Anchor Flange	_____ -8	Grate w/ 8-3/8 x 3-5/8 x 3-3/4 [213 x 92 x 95] High Type 304 Stainless Steel Oval Funnel
_____ -KC	Anchor Flange w/ Seepage Holes and Clamp Collar	_____ -15	Solid Cover
_____ -LSH	(Less) Seepage Holes	_____ -16	1/2 Solid Cover
_____ -P	1/2 [13] Trap Primer Connection	_____ -17	3/4 Solid Cover
_____ -SG	Solid Gasketed Cover	_____ -18	Solid Cover w/ 3 [76] Square Center Opening
_____ -TC	Neo-Loc Test Cap Gasket (2 - 4 [51 - 102] NL Bottom Outlet Only)	_____ -19	Full Hinged Grate
_____ -VP	Vandal-Proof Secured Top	_____ -20	Full Hinged Solid Cover
_____ -Y	Sediment Bucket		
_____ -YS	Suspended Sediment Bucket		
_____ -1	(Less) Grate		
_____ -2	1/2 Grate		

*REGULARLY FURNISHED UNLESS OTHERWISE SPECIFIED

REV. J DATE: 11/18/10 C.N. NO. 120405

DWG. NO. 59307 PRODUCT NO. Z1752

ZURN INDUSTRIES, LLC ♦ SPECIFICATION DRAINAGE OPERATION ♦ 1801 Pittsburgh Ave. ♦ Erie, PA 16514

Phone: 814455-0921 ♦ Fax: 814454-7929 ♦ World Wide Web: www.zurn.com

In Canada: ZURN INDUSTRIES LIMITED ♦ 3544 Nashua Drive ♦ Mississauga, Ontario L4V1L2 ♦ Phone: 905405-8272 Fax: 905405-1292