



Z1926

16 X 16 [406 X 406] A.R.C. SANI-FLOR RECEPTOR 12 [305] SUMP DEPTH

TAG _____

Dimensional Data (inches and [mm]) are Subject to Manufacturing Tolerances and Change Without Notice

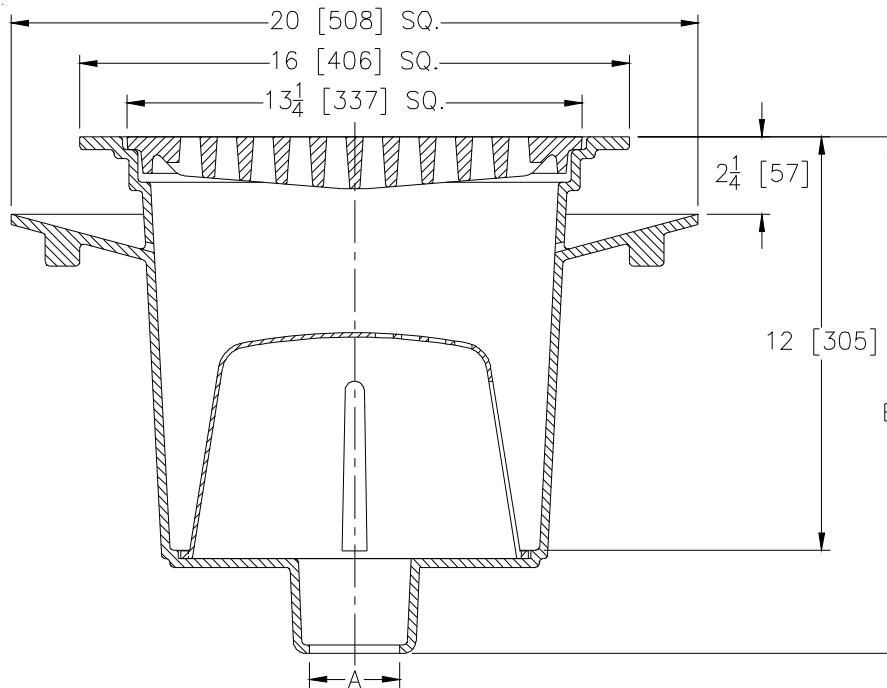

A Pipe Size In.	Approx Wt. Lbs. [kg]	Grate Open Area Sq. In. [cm ²]
2-3-4-5-6-8 [51-76-102-127-152-203]	150 [68]	54 [348]

ENGINEERING SPECIFICATION: ZURN Z1926

Sani-Flor Receptor 16 x 16 x 12 [406 x 406 x 305] deep cast iron body with seepage flange and square, heavy-duty grate with 9/16 [14] slotted openings, white acid resisting epoxy coated interior and top, complete with aluminum anti-splash interior bottom dome strainer.

OPTIONS (Check/specify appropriate options)

PIPE SIZE

2-3-4-6 [51-76-102-152]
2-3-4 [51-76-102]
2-3-4-5-6-8 [51-76-102-127-152-203]

(Specify size/type) **OUTLET**

_____ IC Inside Caulk
_____ NL Neo-Loc
_____ NH No-Hub

'E' BODY HT. DIMENSION

Z	ZN
15 [381]	15-3/16 [386]
14-1/4 [362]	14-7/16 [367]
15 [381]	15-3/16 [386]

PREFIXES

_____ Z Cast Iron Body with White A.R.C. Interior*
_____ ZN Cast Iron Body with White A.R.C. Interior, 16-3/4 [425] Square N.B. Frame and Full Slotted Grate (Add 3/4 [19] to 16 [406] Dim.)

SUFFIXES

_____ -C	Clamp Collar	_____ -11	Vandal-Proof Secured Grate
_____ -LD	Less Bottom Dome Strainer	_____ -15	Solid Loose Set Cover
_____ -P	1/2 [13] Trap Primer Connection	_____ -16	1/2 Solid Loose Set Cover
_____ -TC	Neo-Loc Test Cap Gasket (2 - 4 [51 - 102] NL Bottom Outlet Only)	_____ -17	3/4 Solid Loose Set Cover
_____ -1	Less Grate	_____ -18	Solid Loose Set Cover with 2 [51] Square Center Opening
_____ -2	1/2 Grate	_____ -23	Aluminum Bucket
_____ -3	3/4 Grate	_____ -25	White A.R.C. Bucket
_____ -4	Full Grate with 3-3/4 [95] Center Opening	_____ -31	Stainless Steel Mesh Liner for Bucket
_____ -5	Grate w/ 4 [102] Dia. x 3-3/4 [95] High Funnel	_____ -33	White A.R.C. Anti-Splash Bottom Dome Strainer
_____ -6	Grate w/ 6 [152] Dia. x 6 [152] High Funnel		
_____ -7	Grate w/ 6-3/4 x 3 x 1 [171 x 76 x 25] High Oval Funnel		
_____ -8	Grate w/ 8-7/8 x 3-5/8 x 3-3/4 [225 x 92 x 95] High Oval Funnel		

*REGULARLY FURNISHED UNLESS OTHERWISE SPECIFIED

REV. I DATE: 12/11/12 C.N. NO. 128576

DWG. NO. 59346

PRODUCT NO. Z1926