



Z1970

SPECIFICATION SHEET

9 [229] DIAMETER SHALLOW A.R.C. SANI-FLOR RECEPTOR 3 [76] SUMP DEPTH

TAG _____

Dimensional Data (inches and [mm]) are Subject to Manufacturing Tolerances and Change Without Notice

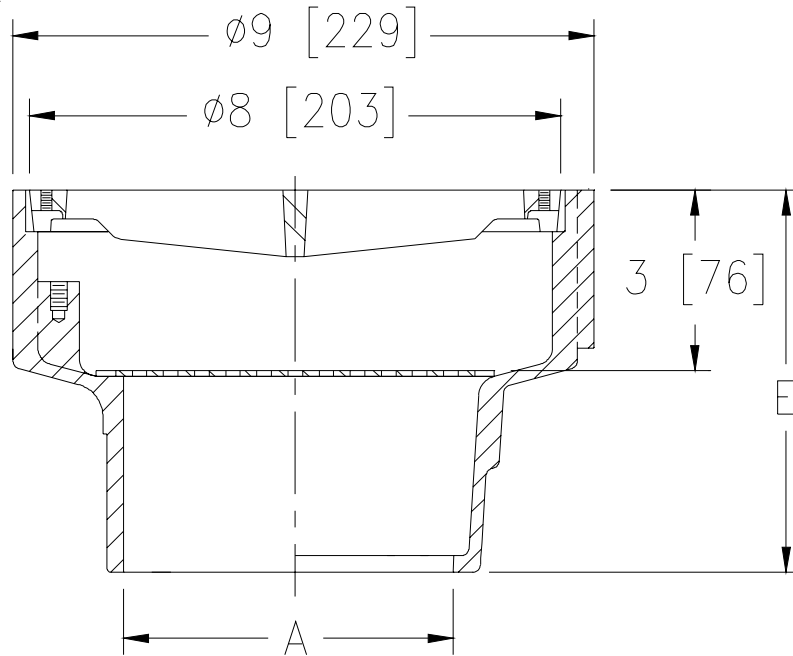

A- Pipe Size In.	Approx Wt. Lbs. [kg]	Grate Open Area Sq. In. [cm ²]
2-3-4 [51-76-102]	14 [6]	18 [116]

ENGINEERING SPECIFICATION: ZURN Z1970

Sani-Flor Receptor 9 [229] Dia. x 3 [76] deep cast iron body and round slotted medium-duty grate, with white acid resisting epoxy coated interior and top, complete with brass secondary strainer.

OPTIONS (Check/specify appropriate options)

PIPE SIZE

2-3-4 [51-76-102]
2-3-4 [51-76-102]
2-3-4 [51-76-102]

(Specify size/type) OUTLET

___ IC Inside Caulk
___ NH No-Hub
___ NL Neo-Loc

'E' BODY HT. DIMENSION

Z	ZN
5-3/4 [146]	6 [152]
5-3/4 [146]	6 [152]
4-7/8 [124]	5-1/8 [152]

PREFIXES

___ Z Cast Iron Body with White A.R.C. Interior*
___ ZN Cast Iron Body with White A.R.C. Interior, 9 [229] Round N.B. Frame and Full Slotted Grate. (Add 11/16 [175] to 9 [229] Dim.)

SUFFIXES

___ -K Anchor Flange	___ -7 Grate w/ 6-3/4 x 3 x 1 [171 x 76 x 25] High Oval Funnel
___ -KC Anchor Flange with Seepage Holes and Clamp Collar	___ -8 Grate w/ 8-7/8 x 3-5/8 x 3-3/4 [225 x 92 x 95] High Oval Funnel
___ -LS (Less) Secondary Strainer	___ -11 Vandal-Proof Secured Grate
___ -P 1/2 [13] Trap Primer Connection	___ -25 White A.R.C. Bucket
___ -TC Neo-Loc Test Cap Gasket (2 - 4 [51-102] NL Bottom Outlet Only)	___ -31 Stainless Steel Mesh Liner for Bucket
___ -1 (Less) Grate	
___ -2 1/2 Grate	
___ -3 3/4 Grate	
___ -4 Full Grate with Center Opening	
___ -5 Grate w/ 4 [102] Dia. x 3-3/4 [95] High Funnel	
___ -6 Grate w/ 6 [152] Dia. x 6 [152] High Funnel	

*REGULARLY FURNISHED UNLESS OTHERWISE SPECIFIED

REV. D DATE: 11/24/10 C.N. NO. 120518

DWG. NO. 59351

PRODUCT NO. Z1970

ZURN INDUSTRIES, LLC. ♦ SPECIFICATION DRAINAGE OPERATION ♦ 1801 Pittsburgh Ave. ♦ Erie, PA 16514

Phone: 814/455-0921 ♦ Fax: 814/454-7929 ♦ World Wide Web: www.zurn.com

In Canada: ZURN INDUSTRIES LIMITED ♦ 3544 Nashua Drive ♦ Mississauga, Ontario L4V1L2 ♦ Phone: 905/405-8272 Fax: 905/405-1292