



Z329
FUNNEL CONVERTING ASSEMBLY

SPECIFICATION SHEET

TAG _____

Dimensional Data (inches and [mm]) are Subject to Manufacturing Tolerances and Change Without Notice

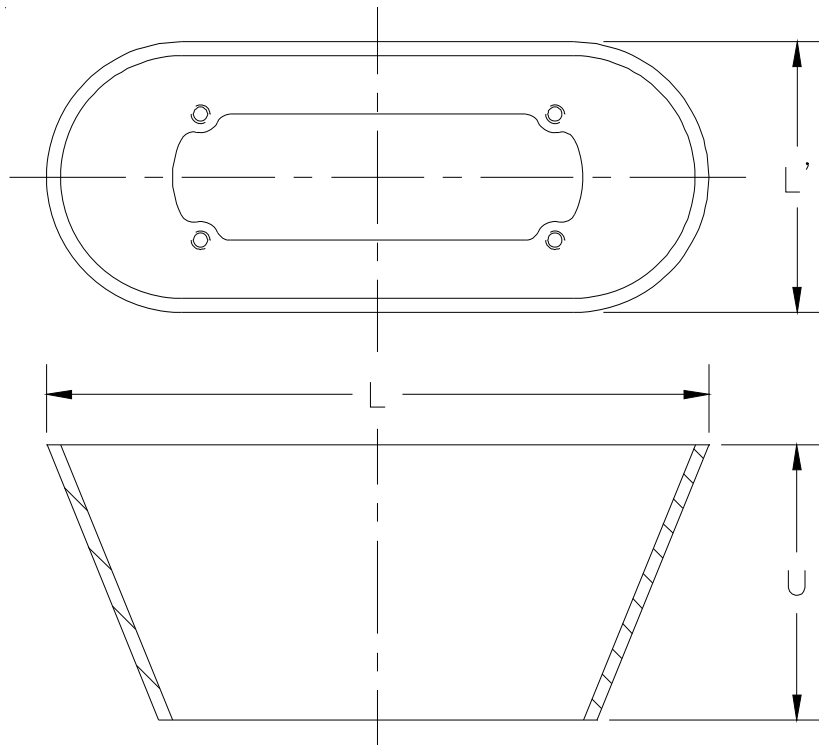

ENGINEERING SPECIFICATION: ZURN Z329
7 [178] or 9 [229] (specify) Oval Funnel Converting Assembly, Dura-Coated cast iron (or finish to suit drain top), with necessary fasteners to secure funnel to strainer. (Available on 7 [178] diameter or larger size drain tops only.)

Product Designation	Dimensions In Inches			Approx. Wt. Lbs. [kg]
	L	L'	U	
-7	6-3/4 [171]	3 [76]	1[25]	2 [1]
-9	8-7/8 [225]	3-5/8 [92]	3-3/4 [95]	4 [2]

OPTIONS (Check/specify appropriate options)

PREFIXES

- ___ Z D.C.C.I. Funnel*
- ___ ZB Polished Bronze Funnel
- ___ ZN Polished Nickel Bronze Funnel

SUFFIXES

- ___ -AR Acid Resisting Epoxy Coated Cast Iron
- ___ -G Galvanized Cast Iron

* Regularly furnished unless otherwise specified.