

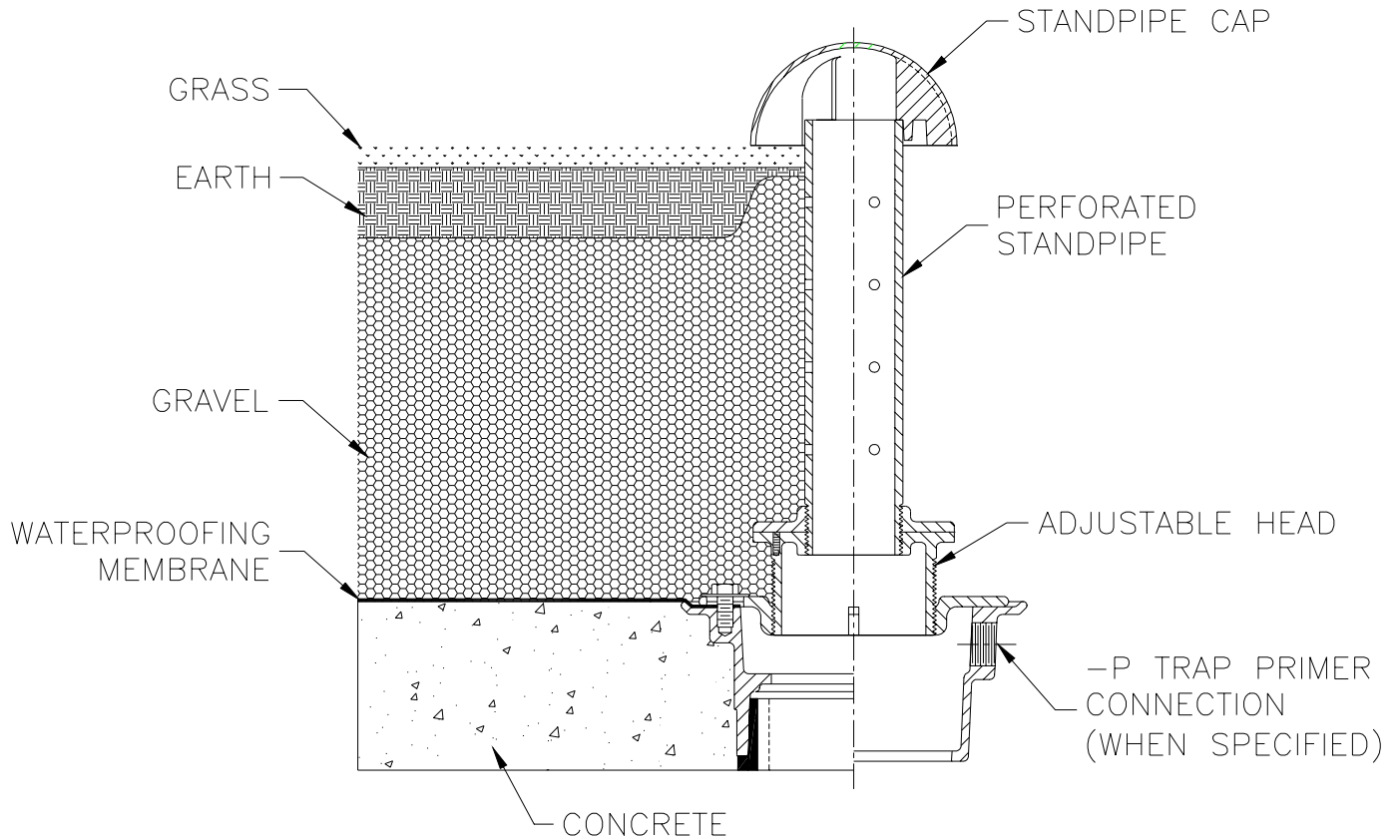

TYPICAL INSTALLATION Z-350 PLANTING AREA DRAIN

Dimensional Data (inches and [mm]) are Subject to Manufacturing Tolerances and Change Without Notice



Z-350 PLANTING AREA DRAIN

Planting Area Drains are ideally suited for indoor atrium areas, outdoor roof top promenade deck areas, and ground level planting areas where excess water must be drained. Perforated standpipe should be encased in gravel to allow adequate percolation. For other available planting area drains see Z-348, Z-349 and Z-352.

Form # FD24

Date: 8/9/99

C.N. No. 83058

Rev.

ZURN INDUSTRIES, INC. ♦ SPECIFICATION DRAINAGE OPERATION ♦ 1801 Pittsburgh Ave. ♦ Erie, PA 16514

Phone: 814/455-0921 ♦ Fax: 814/454-7929 ♦ World Wide Web: www.zurn.com

In Canada: ZURN INDUSTRIES LIMITED ♦ 3544 Nashua Drive ♦ Mississauga, Ontario L4V1L2 ♦ Phone: 905/405-8272 Fax: 905/405-1292