



# Z415C

## BODY ASSEMBLY W/ "TYPE C" STRAINER

SPECIFICATION SHEET

TAG \_\_\_\_\_

Dimensional Data (inches and [ mm ]) are Subject to Manufacturing Tolerances and Change Without Notice

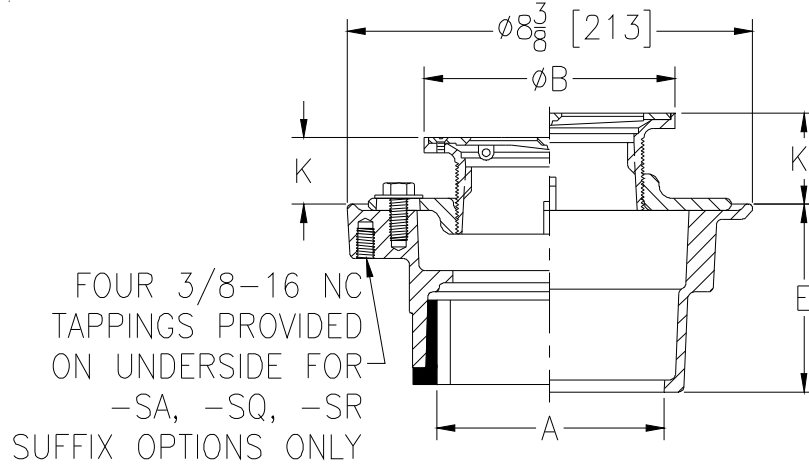

Dimensions In Inches						Approx. Wt. Lbs. [kg]	Strainer Open Area Sq. In. [cm <sup>2</sup> ]
A - Pipe Size	B Strainer Dia.	K		K'			
		Min.	Max.	Min.	Max.		
2-3 [51-76]	5 [127]	1 [25]	1-1/2 [38]	1-3/32 [28]	2-1/4 [57]	11 [5]	8 [52]
2-3-4 [51-76-102]	6 [152]	1 [25]	1-25/32 [45]	1-13/32 [36]	2-17/32 [64]	13 [6]	9 [58]
2-3-4 [51-76-102]	7 [178]	1 [25]	2-1/8 [54]	1-23/32 [44]	2-7/8 [73]	14 [6]	13 [84]
3-4 [76-102]	8 [203]	1-5/32 [29]	2-1/8 [54]	1-3/4 [44]	2-7/8 [73]	16 [7]	18 [116]
6 [152]	8 [203]	1-5/32 [29]	2-1/8 [54]	1-3/4 [44]	2-7/8 [73]	18 [8]	18 [116]

**ENGINEERING SPECIFICATION: ZURN ZN415C**

Floor and shower drain, Dura-Coated cast iron body with bottom outlet, combination invertible membrane clamp and adjustable collar with seepage slots and "TYPE C" polished, hinged nickel bronze, light-duty strainer.

**OPTIONS** (Check/specify appropriate options)

**PIPE SIZE**

- 2 thru 4 [51 thru 102]
- 2 thru 4 [51 thru 102]
- 2 [51]
- 3 [76]
- 4 [102]
- 6 [152]
- 2 thru 4 [51 thru 102]
- 2 thru 4 [51 thru 102]

(Specify size/type) **OUTLET**

- \_\_\_ IC Inside Caulk
- \_\_\_ IG Inside Gasket
- \_\_\_ IP Threaded
- \_\_\_ IP Threaded
- \_\_\_ IP Threaded
- \_\_\_ IP Threaded
- \_\_\_ NH No-Hub
- \_\_\_ NL Neo-Loc

**'E' BODY HT. DIM.**

- 3-7/8 [98]
- 3-7/8 [98]
- 2-3/8 [60]
- 2-5/8 [67]
- 2-7/8 [73]
- 2-3/4 [70]
- 3-7/8 [98]
- 3-3/4 [95]

**PREFIXES**

- \_\_\_ ZB D.C.C.I. Body Assembly w/ Polished Bronze Top
- \_\_\_ ZN D.C.C.I. Body Assembly w/ Polished Nickel Bronze Top\*

**SUFFIXES**

- |   |  |
|---|--|
| <ul style="list-style-type: none"> <li>___ -AR Acid Resisting Epoxy Coated Cast Iron</li> <li>___ -CP Chrome-Plated Bronze Top</li> <li>___ -G Galvanized Cast Iron</li> <li>___ -P Trap Primer Connection (Specify 1/2 [13] or 3/4 [19])</li> <li>___ -SA Stabilizer Assembly (See Z1035)</li> <li>___ -SQ Stabilizer Q-Deck (See Z1035-Q)</li> <li>___ -SR Stabilizer Ring</li> <li>___ -TC Neo-loc Test Cap Gasket<br/>(2 - 4 [51 - 102] NL Bottom Outlet Only)</li> </ul> | <ul style="list-style-type: none"> <li>___ -U 1 - 3 [25 - 76] High Extension Adapter</li> <li>___ -V Backwater Valve</li> <li>___ -VP Vandal-Proof Secured Top</li> <li>___ -Y Sediment Bucket</li> <li>___ -18 Leveling Ring (See Z400-18)</li> <li>___ -90 90° Threaded Side Outlet Body Assembly (2 [51], 3 [76] Only)</li> </ul> |
|---|--|

\*REGULARLY FURNISHED UNLESS OTHERWISE SPECIFIED

<b>REV. K</b>	<b>DATE: 06/21/11</b>	<b>C.N. NO. 121443</b>
<b>DWG. NO. 58791</b>	<b>PRODUCT NO. Z415C</b>	

ZURN INDUSTRIES, LLC. ♦ SPECIFICATION DRAINAGE OPERATION ♦ 1801 Pittsburgh Ave. ♦ Erie, PA 16514

Phone: 814/455-0921 ♦ Fax: 814/454-7929 ♦ World Wide Web: www.zurn.com

In Canada: ZURN INDUSTRIES LIMITED ♦ 3544 Nashua Drive ♦ Mississauga, Ontario L4V1L2 ♦ Phone: 905/405-8272 Fax: 905/405-1292