



Z415E

BODY ASSEMBLY W/ "TYPE E" STRAINER

SPECIFICATION SHEET

TAG _____

Dimensional Data (inches and [mm]) are Subject to Manufacturing Tolerances and Change Without Notice

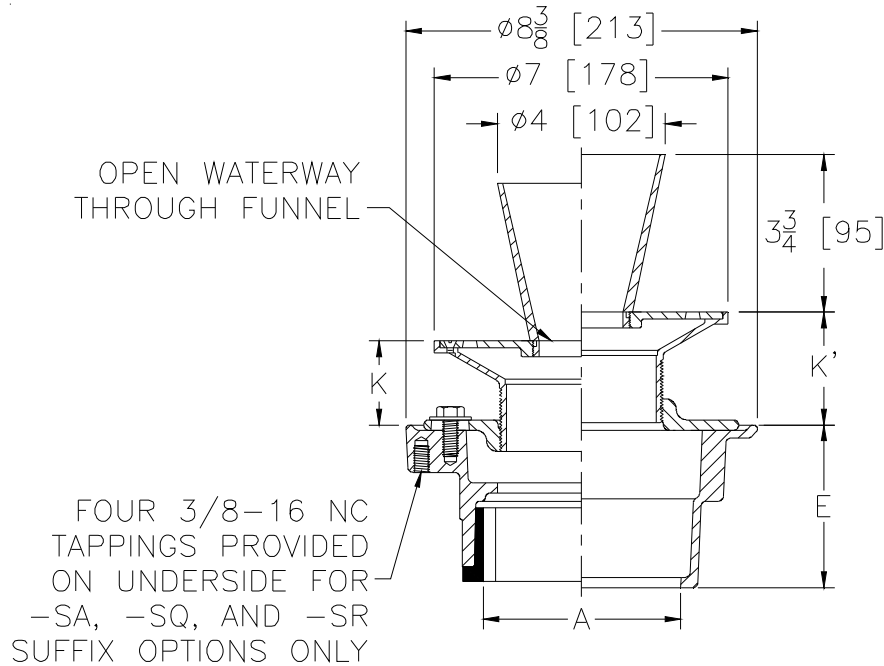

Dimensions In Inches					Approx. Wt. Lbs. [kg]	Strainer Open Area Sq. In. [cm ²]
A - Pipe Size	K		K'			
	Min.	Max.	Min.	Max.		
2-3-4 [51-76-102]	1 [25]	2-1/8 [54]	1-5/8 [41]	2-15/16 [75]	19 [9]	5 [32]

ENGINEERING SPECIFICATION: ZURN ZN415E

Floor and shower drain, Dura-Coated cast iron body with bottom outlet, combination invertible membrane clamp and adjustable collar with seepage slots and "TYPE E" polished, nickel bronze strainer with 4 [102] diameter funnel.

OPTIONS (Check/specify appropriate options)

PIPE SIZE

- 2 thru 4 [51 thru 102]
- 2 thru 4 [51 thru 102]
- 2 [51]
- 3 [76]
- 4 [102]
- 2 thru 4 [51 thru 102]
- 2 thru 4 [51 thru 102]

OUTLET (Specify size/type)

- _____ IC Inside Caulk
- _____ IG Inside Gasket
- _____ IP Threaded
- _____ IP Threaded
- _____ IP Threaded
- _____ NH No-Hub
- _____ NL Neo-Loc

'E' BODY HT. DIM.

- 3-7/8 [98]
- 3-7/8 [98]
- 2-3/8 [60]
- 2-5/8 [67]
- 2-7/8 [73]
- 3-7/8 [98]
- 3-3/4 [95]

PREFIXES

- _____ ZB D.C.C.I. Body Assembly w/ Polished Bronze Top
- _____ ZN D.C.C.I. Body Assembly w/ Polished Nickel Bronze Top*

SUFFIXES

- | | |
|--|--|
| <ul style="list-style-type: none"> _____ -AR Acid Resisting Epoxy Coated Cast Iron _____ -G Galvanized Cast Iron _____ -P Trap Primer Connection (Specify 1/2 [13] or 3/4 [19]) _____ -SA Stabilizer Assembly (See Z1035) _____ -SC Solid Cover _____ -SQ Stabilizer Q-Deck (See Z1035-Q) _____ -SR Stabilizer Ring _____ -TC Neo-Loc Test Cap Gasket
(2-4 [51-102] NL Bottom Outlet Only) | <ul style="list-style-type: none"> _____ -U 1-3 [25-76] High Extension Adapter _____ -V Backwater Valve _____ -VP Vandal-Proof Secured Top _____ -Y Sediment Bucket _____ -18 Leveling Ring (See Z400-18) _____ -90 90° Threaded Side Outlet Body
Assembly (2 [51], 3 [76] Only) |
|--|--|

*REGULARLY FURNISHED UNLESS OTHERWISE SPECIFIED

REV. M	DATE: 06/21/11	C.N. NO. 121445
DWG. NO. 58793	PRODUCT NO. Z415E	

ZURN INDUSTRIES, LLC ♦ SPECIFICATION DRAINAGE OPERATION ♦ 1801 Pittsburgh Ave. ♦ Erie, PA 16514

Phone: 814/455-0921 ♦ Fax: 814/454-7929 ♦ World Wide Web: www.zurn.com

In Canada: ZURN INDUSTRIES LIMITED ♦ 3544 Nashua Drive ♦ Mississauga, Ontario L4V1L2 ♦ Phone: 905/405-8272 Fax: 905/405-1292