



Z415G

BODY ASSEMBLY

W/ "TYPE G" STRAINER

SPECIFICATION SHEET

TAG _____

Dimensional Data (inches and [mm]) are Subject to Manufacturing Tolerances and Change Without Notice

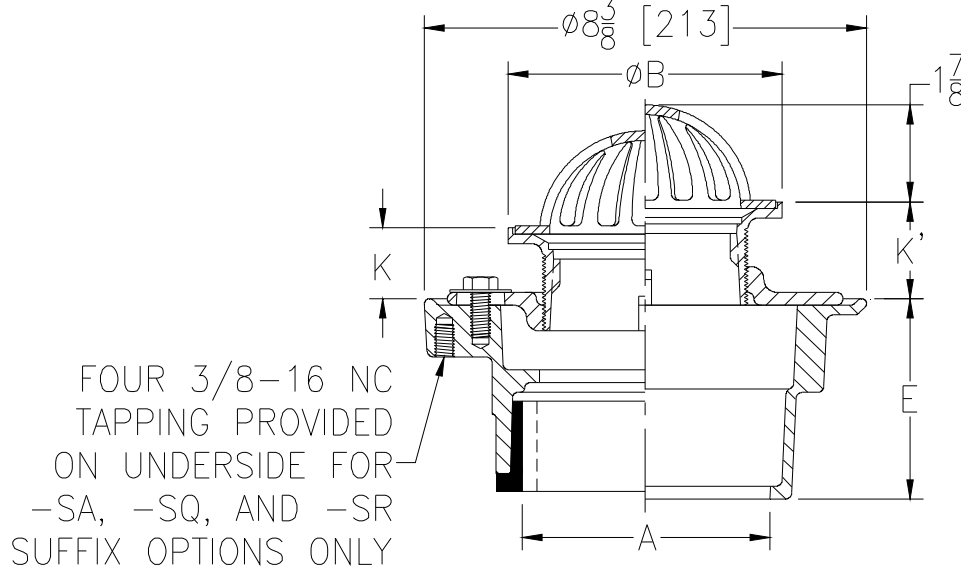

Dimensions In Inches						Approx. Wt. Lbs. [kg]	Strainer Open Area Sq. In. [cm ²]
A - Pipe Size	B Strainer Dia.	K		K'			
		Min.	Max.	Min.	Max.		
2-3 [51-76]	5 [127]	1 [25]	1-1/2 [38]	1-3/32 [28]	2-1/4 [57]	11 [5]	10 [65]
2-3-4 [51-76-102]	6 [152]	1 [25]	1-25/32 [45]	1-13/32 [36]	2-17/32 [64]	13 [6]	12 [77]

ENGINEERING SPECIFICATION: ZURN ZN415G

Floor and shower drain, Dura-Coated cast iron body with bottom outlet, combination invertible membrane clamp and adjustable collar with seepage slots and "TYPE G" polished nickel bronze strainer with dome grate.

OPTIONS (Check/specify appropriate options)

PIPE SIZE	(Specify size/type) OUTLET	'E' BODY HT. DIM.
2 thru 4 [51 thru 102]	___ IC Inside Caulk	3-7/8 [98]
2 thru 4 [51 thru 102]	___ IG Inside Gasket	3-7/8 [98]
2 [51]	___ IP Threaded	2-3/8 [60]
3 [76]	___ IP Threaded	2-5/8 [67]
4 [102]	___ IP Threaded	2-7/8 [73]
2 thru 4 [51 thru 102]	___ NH No-Hub	3-7/8 [98]
2 thru 4 [51 thru 102]	___ NL Neo-Loc	3-3/4 [95]

PREFIXES

- ___ ZB D.C.C.I. Body Assembly w/ Polished Bronze Top
- ___ ZN D.C.C.I. Body Assembly w/ Polished Nickel Bronze Top*

SUFFIXES

- | | |
|---|--|
| ___ -AR Acid Resisting Epoxy Coated Cast Iron | ___ -U 1 thru 3 [25 thru 76] High Extension Adapter |
| ___ -BS Bronze Mesh Screen Over Dome | ___ -V Backwater Valve |
| ___ -CP Chrome-Plated Bronze Top | ___ -VP Vandal-Proof Secured Top |
| ___ -G Galvanized Cast Iron | ___ -Y Sediment Bucket |
| ___ -P Trap Primer Connection (Specify 1/2 [13] or 3/4 [19]) | ___ -18 Leveling Ring (See Z400-18) |
| ___ -SA Stabilizer Assembly (See Z1035) | ___ -90 90° Threaded Side Outlet Body Assembly (2 [51], 3 [76] Only) |
| ___ -SQ Stabilizer Q-Deck (See Z1035-Q) | |
| ___ -SR Stabilizer Ring | |
| ___ -SS Stainless Steel Mesh Screen Over Dome | |
| ___ -TC Neo-Loc Test Cap Gasket
(2 - 4 [51 - 102] NL Bottom Outlet Only) | |

*REGULARLY FURNISHED UNLESS OTHERWISE SPECIFIED

REV. L	DATE: 06/21/11	C.N. NO. 121446
DWG. NO. 58794	PRODUCT NO. Z415G	

ZURN INDUSTRIES, LLC ♦ SPECIFICATION DRAINAGE OPERATION ♦ 1801 Pittsburgh Ave. ♦ Erie, PA 16514

Phone: 814-455-0921 ♦ Fax: 814-454-7929 ♦ World Wide Web: www.zurn.com

In Canada: ZURN INDUSTRIES LIMITED ♦ 3544 Nashua Drive ♦ Mississauga, Ontario L4V1L2 ♦ Phone: 905-405-8272 Fax: 905-405-1292