



Z415H

BODY ASSEMBLY W/ "TYPE H" STRAINER

SPECIFICATION SHEET

TAG _____

Dimensional Data (inches and [mm]) are Subject to Manufacturing Tolerances and Change Without Notice

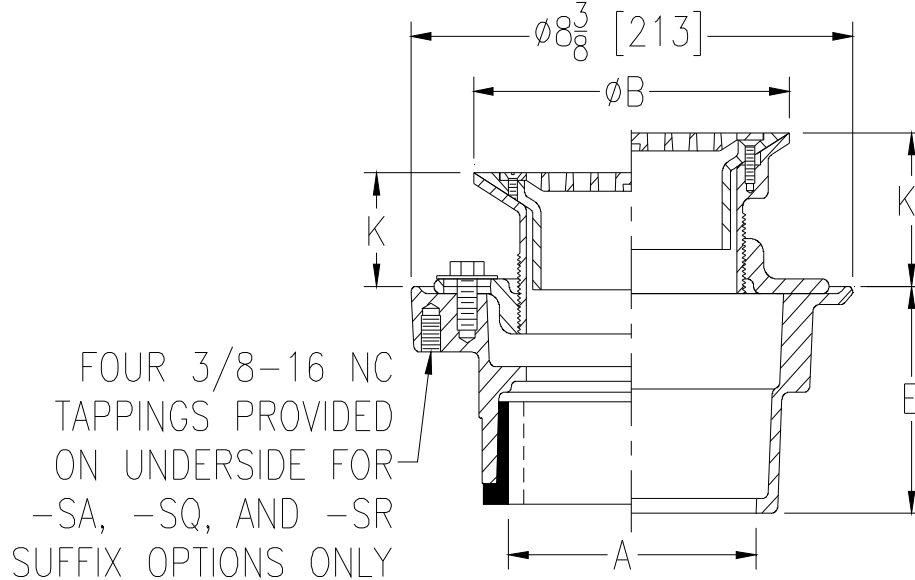

| Dimensions In Inches | | | | | | Approx. Wt. Lbs. [kg] | Strainer Open Area Sq. In. [cm ²] |
|----------------------|--------------|--------------|------------|-------------|-------------|-----------------------|---|
| A - Pipe Size | B - Top Size | K | | K' | | | |
| | | Min. | Max. | Min. | Max. | | |
| 2-3-4 [51-76-102] | 6 [152] | 1-1/4 [32] | 2-3/8 [60] | 2-3/16 [56] | 3-5/16 [84] | 13 [6] | 7 [45] |
| | 9 [229] | 1-11/16 [43] | 2-5/8 [66] | 2-7/16 [62] | 3-9/16 [90] | 20 [9] | 18 [116] |

ENGINEERING SPECIFICATION: ZURN ZN415H

Floor and shower drain, Dura-Coated cast iron body with bottom outlet, combination invertible membrane clamp and adjustable collar with seepage slots and "TYPE H" polished nickel bronze, light-duty strainer with flashing clamp device for clamping at the finished floor level.

OPTIONS (Check/specify appropriate options)

| PIPE SIZE | (Specify size/type) | OUTLET | 'E' BODY HT. DIM. |
|------------------------|---------------------|-----------------|-------------------|
| 2 thru 4 [51 thru 102] | _____ | IC Inside Caulk | 3-7/8 [98] |
| 2 [51] | _____ | IP Threaded | 2-3/8 [60] |
| 3 [76] | _____ | IP Threaded | 2-5/8 [67] |
| 4 [102] | _____ | IP Threaded | 2-7/8 [73] |
| 2 thru 4 [51 thru 102] | _____ | NH No-Hub | 3-7/8 [98] |
| 2 thru 4 [51 thru 102] | _____ | NL Neo-Loc | 3-3/4 [95] |

PREFIXES

- _____ ZB D.C.C.I. Body Assembly w/ Polished Bronze Top
- _____ ZN D.C.C.I. Body Assembly w/ Polished Nickel Bronze Top*

SUFFIXES

- | | |
|--|--|
| _____ -AR Acid Resisting Epoxy Coated Cast Iron | _____ -VP Vandal-Proof Secured Top |
| _____ -G Galvanized Cast Iron | _____ -Y Sediment Bucket |
| _____ -P Trap Primer Connection (Specify 1/2 [13] or 3/4 [19]) | _____ -18 Leveling Ring (See Z400-18) |
| _____ -SA Stabilizer Assembly (See Z1035) | _____ -90 90° Threaded Side Outlet Body Assembly (See Z1043) |
| _____ -SQ Stabilizer Q-Deck (See Z1035-Q) | |
| _____ -SR Stabilizer Ring | |
| _____ -U 1 - 3 [25 - 76] High Extension Adapter | |
| _____ -V Backwater Valve | |

| | | |
|----------------|-------------------|-----------------|
| REV. L | DATE: 06/21/11 | C.N. NO. 121447 |
| DWG. NO. 58795 | PRODUCT NO. Z415H | |

*REGULARLY FURNISHED UNLESS OTHERWISE SPECIFIED