



Z415I

BODY ASSEMBLY W/ "TYPE I" STRAINER

SPECIFICATION SHEET

TAG _____

Dimensional Data (inches and [mm]) are Subject to Manufacturing Tolerances and Change Without Notice

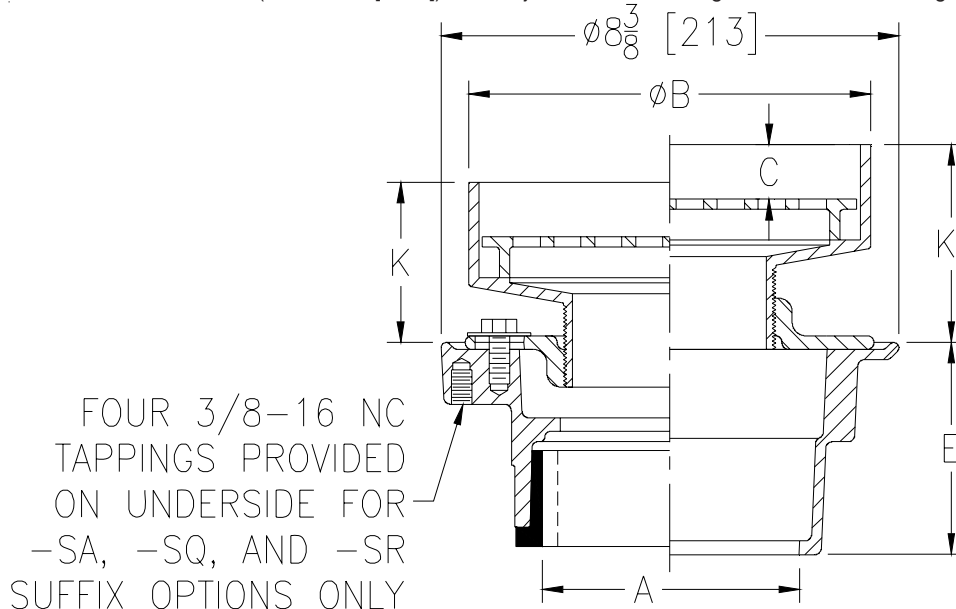

Dimensions In Inches							Approx. Wt. Lbs. [kg]	Strainer Open Area Sq. In. [cm ²]
A - Pipe Size	B Strainer Dia.	C	K		K'			
			Min.	Max.	Min.	Max.		
2-3 [51-76]	5-7/16 [138]	7/8 [22]	1-9/16 [40]	2-5/8 [67]	2-1/8 [54]	3-3/8 [86]	14 [6]	8 [52]
2-3-4 [51-76-102]	7-3/8 [187]	1 [25]	2-9/16 [65]	3-3/8 [86]	2-7/8 [73]	4-1/8 [105]	19 [9]	13 [84]
3-4 [76-102]	9 [229]	1/2 [13]	2-3/16 [56]	3-1/8 [79]	2-5/8 [67]	3-7/8 [98]	23 [10]	23 [148]
6 [152]	9 [229]	1/2 [13]	2-3/16 [56]	3-1/8 [79]	2-5/8 [67]	3-7/8 [98]	23 [10]	23 [148]

ENGINEERING SPECIFICATION: ZURNZN415I

Floor and shower drain, Dura-Coated cast iron body with bottom outlet, combination invertible membrane clamp and adjustable collar with seepage slots and "TYPE I" polished nickel bronze strainer with raised flange.

OPTIONS (Check/specify appropriate options)

PIPE SIZE

- 2 thru 4 [51 thru 102]
- 2 thru 4 [51 thru 102]
- 2 [51]
- 3 [76]
- 4 [102]
- 6 [152]
- 2 thru 4 [51 thru 102]
- 2 thru 4 [51 thru 102]

(Specify size/type) **OUTLET**

- _____ IC Inside Caulk
- _____ IG Inside Gasket
- _____ IP Threaded
- _____ IP Threaded
- _____ IP Threaded
- _____ IP Threaded
- _____ NH No-Hub
- _____ NL Neo-Loc

'E' BODY HT. DIM.

- 3-7/8 [98]
- 3-7/8 [98]
- 2-3/8 [60]
- 2-5/8 [67]
- 2-7/8 [73]
- 2-3/4 [70]
- 3-7/8 [98]
- 3-3/4 [95]

PREFIXES

- _____ ZB D.C.C.I. Body Assembly w/ Polished Bronze Top
- _____ ZN D.C.C.I. Body Assembly w/ Polished Nickel Bronze Top*

SUFFIXES

- _____ -AR Acid Resisting Epoxy Coated Cast Iron
- _____ -G Galvanized Cast Iron
- _____ -P Trap Primer Connection (Specify 1/2 [13] or 3/4 [19])
- _____ -SA Stabilizer Assembly (See Z1035)
- _____ -SQ Stabilizer Q-Deck (See Z1035-Q)
- _____ -SR Stabilizer Ring
- _____ -TC Neo-Loc Test Cap Gasket
(2 - 4 [51 - 76] NL Bottom Outlet Only)
- _____ -TS Top Secured with Slotted Screws
- _____ -U 1 - 3 [25 - 76] High Extension Adapter
- _____ -V Backwater Valve
- _____ -VP Vandal-Proof Secured Top
- _____ -Y Sediment Bucket
- _____ -18 Leveling Ring (See Z400-18)
- _____ -90 90° Threaded Side Outlet Body
Assembly (2 [51], 3 [76] Only)

*REGULARLY FURNISHED UNLESS OTHERWISE SPECIFIED

REV. M	DATE: 07/29/11	C.N. NO. 121769
DWG. NO. 58797	PRODUCT NO. Z415I	