



# Z415SH

## BODY ASSEMBLY

### W/ "TYPE SH" STRAINER

SPECIFICATION SHEET

TAG \_\_\_\_\_

Dimensional Data (inches and [ mm ]) are Subject to Manufacturing Tolerances and Change Without Notice

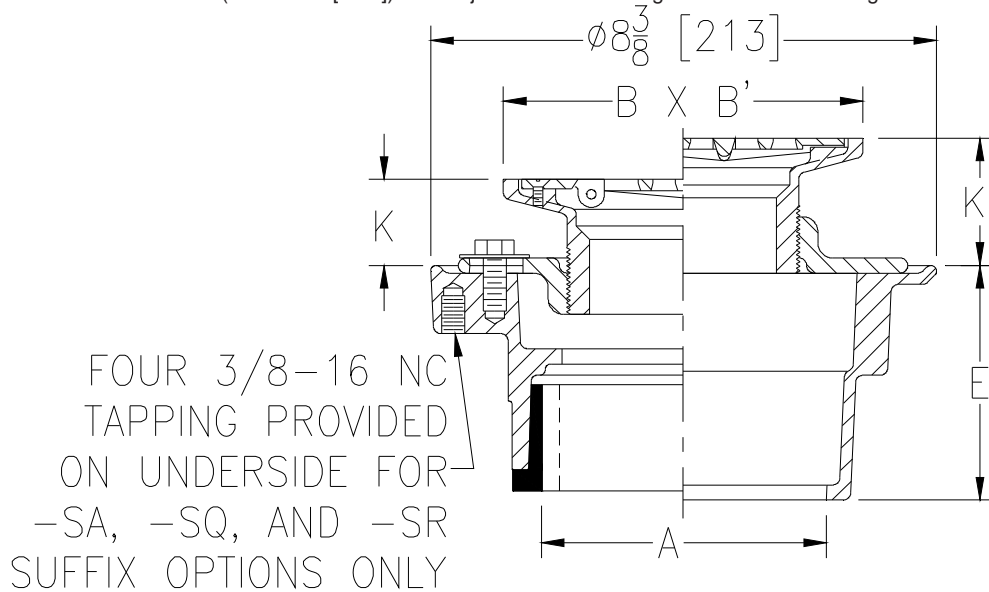

Dimensions In Inches						Approx. Wt. Lbs. [kg]	Strainer Open Area Sq. In. [cm <sup>2</sup> ]
A - Pipe Size	B x B' Strainer Top Size	K		K'			
		Min.	Max.	Min.	Max.		
2-3-4 [51-76-102]	6 x 6 [152 x 152]	1 [25]	1-7/8 [48]	1-3/4 [44]	2-5/8 [67]	13 [6]	12 [77]
2-3-4 [51-76-102]	8 x 8 [203 x 203]	1-5/32 [29]	2 [51]	2 [51]	2-3/4 [70]	17 [8]	21 [135]
6 [152]	8 x 8 [203 x 203]	1-5/32 [29]	2 [51]	2 [51]	2-3/4 [70]	19 [9]	21 [135]

**ENGINEERING SPECIFICATION:** ZURN ZN415SH

Floor and shower drain, Dura-Coated cast iron body with bottom outlet, combination invertible membrane clamp and adjustable collar with seepage slots and "TYPE SH" polished nickel bronze, square hinged, light-duty strainer.

**OPTIONS** (Check/specify appropriate options)

PIPE SIZE	(Specify size/type) OUTLET	'E' BODY HT. DIM.
2 thru 4 [51 thru 102]	_____ IC Inside Caulk	3-7/8 [98]
2 thru 4 [51 thru 102]	_____ IG Inside Gasket	3-7/8 [98]
2 [51]	_____ IP Threaded	2-3/8 [60]
3 [76]	_____ IP Threaded	2-5/8 [67]
4 [102]	_____ IP Threaded	2-7/8 [73]
6 [152]	_____ IP Threaded	2-3/4 [70]
2 thru 4 [51 thru 102]	_____ NH No-Hub	3-7/8 [98]
2 thru 4 [51 thru 102]	_____ NL Neo-Loc	3-3/4 [95]

**PREFIXES**

- \_\_\_\_\_ ZB D.C.C.I. Body Assembly w/ Polished Bronze Top
- \_\_\_\_\_ ZN D.C.C.I. Body Assembly w/ Polished Nickel Bronze Top\*

**SUFFIXES**

- |   |  |
|---|--|
| _____ -AR Acid Resisting Epoxy Coated Cast Iron                     | _____ -V Backwater Valve   |
| _____ -G Galvanized Cast Iron                                       | _____ -VP Vandal-Proof   |
| _____ -P Trap Primer Connection (Specify 1/2 [13] or 3/4 [19])      | _____ -Y Sediment Bucket   |
| _____ -SA Stabilizer Assembly (See Z1035)                           | _____ -18 Leveling Ring (See Z400-18)                                  |
| _____ -SQ Stabilizer Q-Deck (See Z1035-Q)                           | _____ -90 90° Threaded Side Outlet Body Assembly (2 [51], 3 [76] Only) |
| _____ -SR Stabilizer Ring   |  |
| _____ -TC Neo-Loc Test Cap Gasket (2 - 4 [51 - 102] NL Outlet Only) |  |
| _____ -U 1 - 3 [25 - 76] High Extension Adapter                     |  |

<b>REV. I</b>	<b>DATE: 06/21/11</b>	<b>C.N. NO. 121457</b>
<b>DWG. NO. 58804</b>		<b>PRODUCT NO. Z415SH</b>

\*REGULARLY FURNISHED UNLESS OTHERWISE SPECIFIED