



# Z455B

## TRAP DRAIN W/ FLOOR CLEANOUT & "TYPE B" STRAINER

SPECIFICATION SHEET

TAG \_\_\_\_\_

Dimensional Data (inches and [ mm ]) are Subject to Manufacturing Tolerances and Change Without Notice

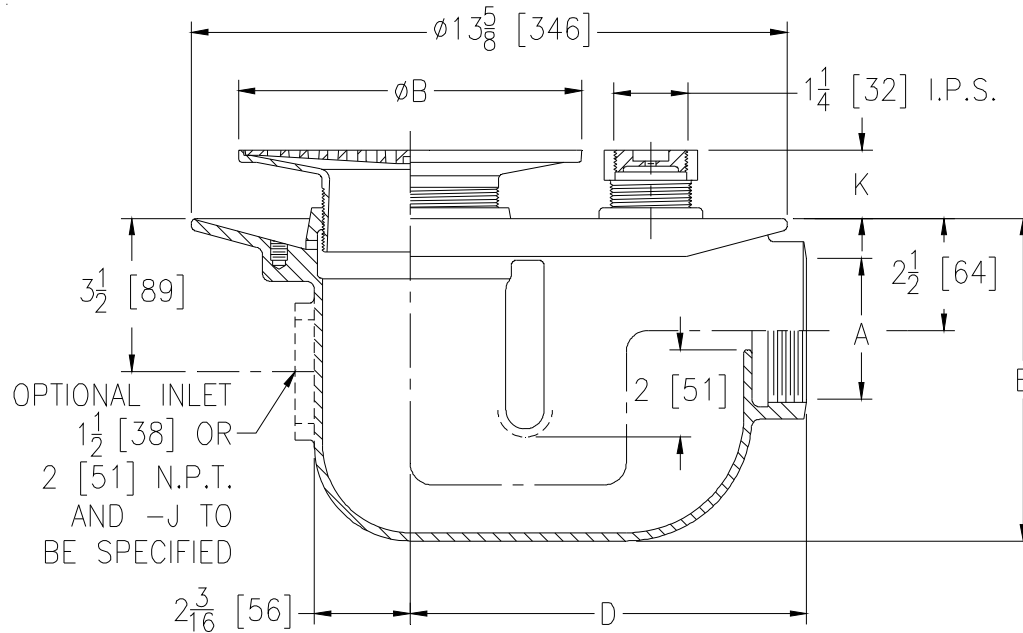

Dimensions In Inches				Approx. Wt. Lbs. [kg]	Strainer Open Area Sq. In. [cm <sup>2</sup> ]
A Pipe Size	B Strainer Dia.	K			
		Min.	Max.		
2-3-4 [51-76-102]	5 [127]	7/8 [22]	2 [51]	37 [17]	8 [52]
2-3-4 [51-76-102]	6 [152]	1-1/8 [29]	2-1/4 [57]	39 [18]	9 [58]
2-3-4 [51-76-102]	7 [178]	1-1/2 [38]	2-5/8 [67]	41 [19]	12 [77]
2-3-4 [51-76-102]	8 [203]	1-1/2 [38]	2-5/8 [67]	43 [20]	18 [116]

### ENGINEERING SPECIFICATION:

ZURN ZN455B

Floor and shower trap drain, Dura-Coated cast iron body with integral trap, side outlet, seepage pan, floor level cleanout and adjustable "TYPE B" polished, nickel bronze, light-duty strainer.

### OPTIONS (Check/specify appropriate options)

#### PIPE SIZE

2-3 [51-76]  
4 [102]  
2-3-4 [51-76-102]

#### (Specify size/type) OUTLET

\_\_\_ IP Threaded  
\_\_\_ IP Threaded  
\_\_\_ NH No-Hub (IP w/ Z1040)

#### 'D'

9-1/16 [230]  
9-5/16 [237]  
11-3/4 [298]

#### 'E'

7-3/8 [187]  
7-3/8 [187]  
7-3/8 [187]

### PREFIXES

\_\_\_ ZB D.C.C.I. Body Assembly w/ Polished Bronze Top  
\_\_\_ ZN D.C.C.I. Body Assembly w/ Polished Nickel Bronze Top\*

### SUFFIXES

\_\_\_ -C Clamping Collar  
\_\_\_ -DC Debris Cover  
\_\_\_ -FC Flush Cover for Plug  
\_\_\_ -G Galvanized Cast Iron  
\_\_\_ -J Auxiliary Inlet (Specify 1-1/2 [38] or 2 [51])  
\_\_\_ -P Trap Primer Connection (Specify 1/2 [13] or 3/4 [19])  
\_\_\_ -PC Protective Cover  
\_\_\_ -V Backwater Valve (Ball Float Type)  
\_\_\_ -VP Vandal-Proof Secured Top  
\_\_\_ -Y Sediment Bucket

\* Regularly furnished unless otherwise specified.