



# Z503

## 15 [381] HEAVY-DUTY AREA DRAIN

SPECIFICATION SHEET

TAG \_\_\_\_\_

Dimensional Data (inches and [ mm ]) are Subject to Manufacturing Tolerances and Change Without Notice

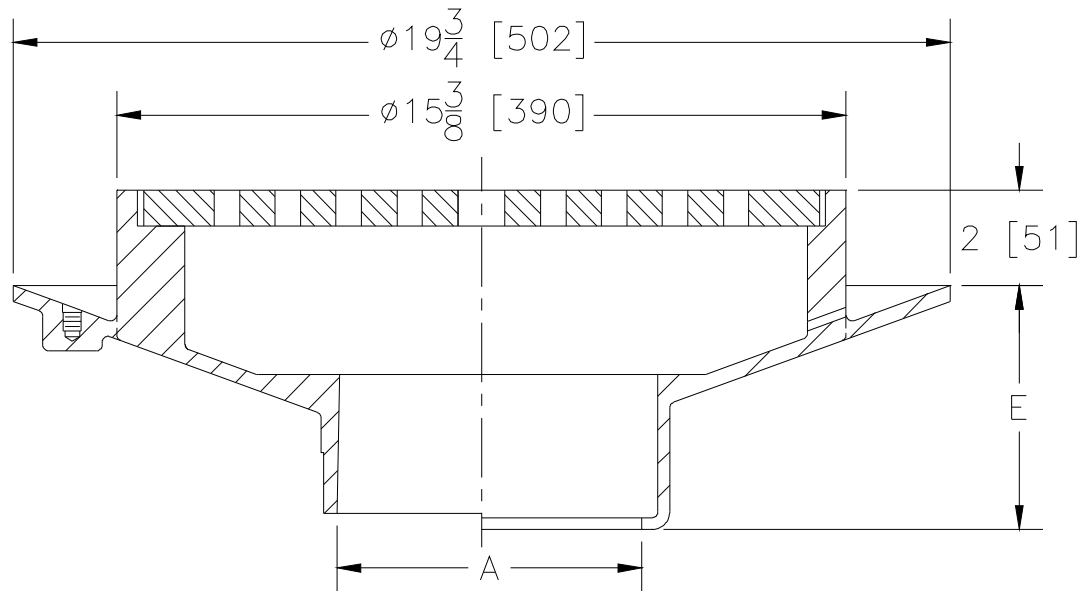

A- Pipe Size In.	Approx. Wt. Lbs. [kg]	Grate Open Area Sq. In. [cm <sup>2</sup> ]
3-4-5-6-8 [76-102-127-152-203]	90 [41]	45 [290]

**ENGINEERING SPECIFICATION:** ZURN Z503 15 [381] Diameter top drain, Dura-Coated cast iron body with bottom outlet, seepage pan and heavy-duty anti-tilt slotted grate.

**OPTIONS** (Check/specify appropriate options)

**PIPE SIZE**

- 3 thru 6 [76 thru 152]
- 8 [203]
- 3-4-6 [76-102-152]
- 3 thru 6-8 [76 thru 152-203]
- 4 [102]

(Specify size/type) **OUTLET**

- \_\_\_ IC Inside Caulk
- \_\_\_ IC Inside Caulk
- \_\_\_ IG Inside Gasket
- \_\_\_ IP Threaded
- \_\_\_ NL Neo-Loc

**'E' BODY HT. DIM.**

- 5 1/8 [130]
- 5 5/8 [143]
- 5 1/8 [130]
- 3 [76]
- 3 7/8 [98]

**PREFIXES**

- \_\_\_ Z D.C.C.I. Body and Top\*
- \_\_\_ ZB D.C.C.I. Body with Polished Bronze Top (Add 3/16 [5] to 2 [51] Dim.)
- \_\_\_ ZN D.C.C.I. Body with Polished Nickel Bronze Top (Add 3/16 [5] to 2 [51] Dim.)

**SUFFIXES**

- \_\_\_ -AR Acid Resisting Epoxy Coated Cast Iron
- \_\_\_ -C Clamp Collar
- \_\_\_ -DG Duresist Grate
- \_\_\_ -G Galvanized Cast Iron
- \_\_\_ -S Secondary Strainer
- \_\_\_ -TC Neo-Loc Test Cap Gasket (4 [102] NL Bottom Outlet Only)
- \_\_\_ -TS Top Secured with Slotted Screws
- \_\_\_ -V Backwater Valve (See Z1099)
- \_\_\_ -VP Vandal-Proof Secured Top
- \_\_\_ -Y Sediment Bucket

<b>REV. E</b>	<b>DATE: 11/16/10</b>	<b>C.N. NO. 120409</b>
<b>DWG. NO. 58920</b>		<b>PRODUCT NO. Z503</b>

\*REGULARLY FURNISHED UNLESS OTHERWISE SPECIFIED