

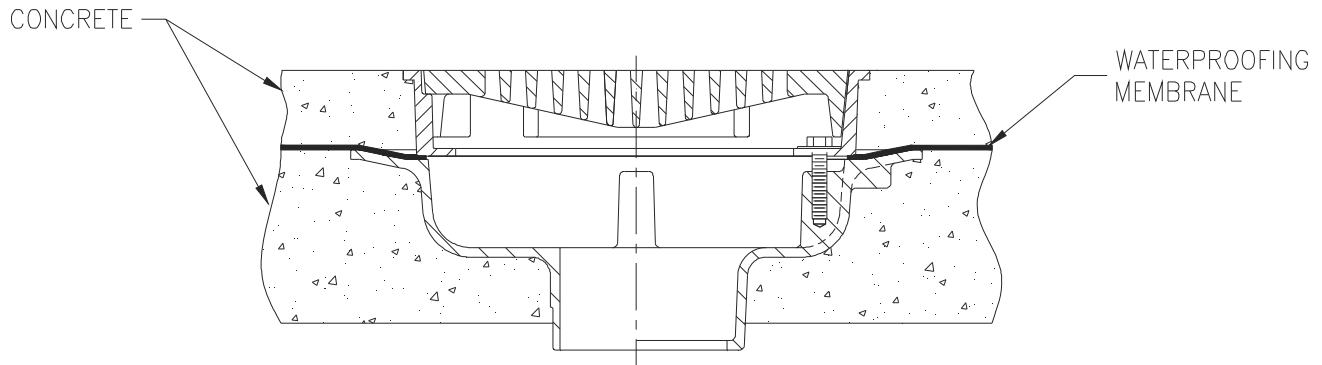

TYPICAL INSTALLATION  
**Z505**  
12 [305] DIAMETER HEAVY-DUTY DRAIN

Dimensional data (inches and [mm]) are subject to manufacturing tolerances and change without notice.



**Z505 FLOOR DRAIN**

12 [305] diameter Heavy-Duty drain installed in a multiple poured concrete slab with waterproofing membrane secured with combination flashing clamp and frame.

\* Regularly furnished unless otherwise specified.

Zurn Industries, LLC | Light Commercial Plumbing Products  
1801 Pittsburgh Avenue, Erie, PA U.S.A. 16502 · Ph. 855-663-9876, Fax 814-454-7929  
In Canada | Zurn Industries Limited  
3544 Nashua Drive, Mississauga, Ontario L4V 1L2 · Ph. 905-405-8272, Fax 905-405-1292  
[www.zurn.com](http://www.zurn.com)

Rev. -  
Date: 07/23/14  
C.N. No. 131250  
Form # FD93