



Z507

7 [178] MEDIUM DUTY DRAIN

SPECIFICATION SHEET

TAG _____

Dimensional Data (inches and [mm]) are Subject to Manufacturing Tolerances and Change Without Notice

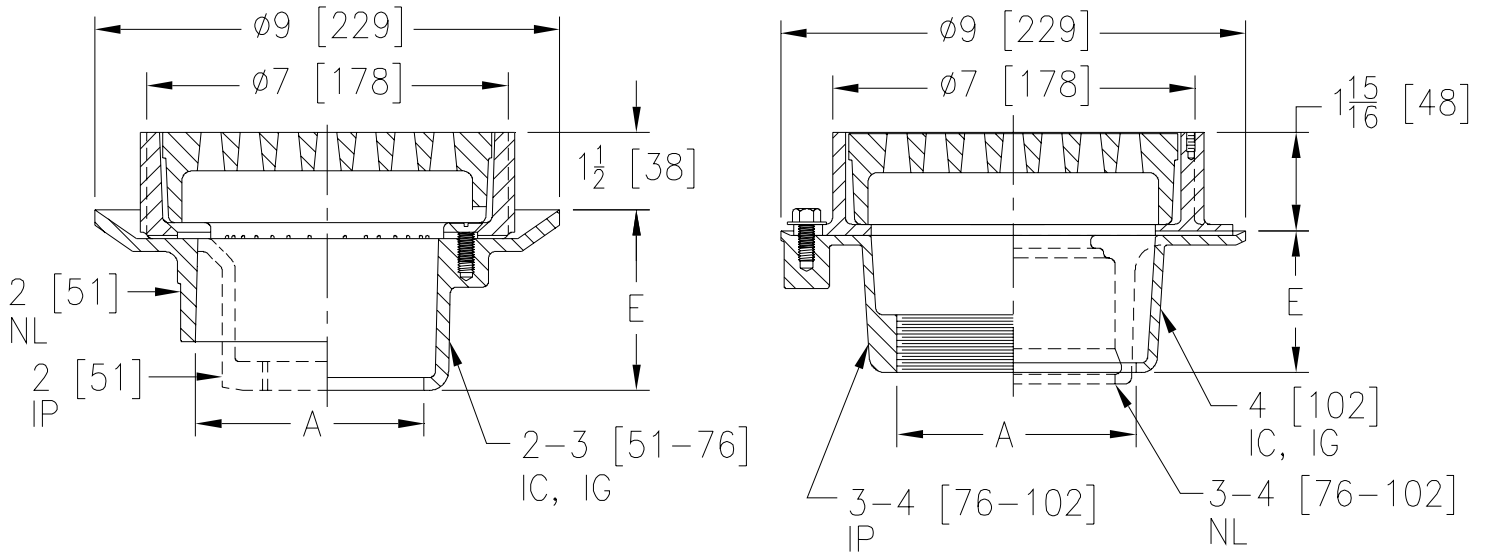

A Pipe Size In.	Approx. Wt. Lbs. [kg]	Grate Open Area Sq. In. [cm ²]
2-3-4 [51-76-102]	15 [7]	9 [58]

ENGINEERING SPECIFICATION: ZURN Z507

7 [178] Diameter top drain, Dura-Coated cast iron body with bottom outlet, seepage pan and combination membrane flashing clamp and frame for medium-duty cast iron deep flange slotted grate.

OPTIONS (Check/specify appropriate options)

PIPE SIZE

- 2-3 [51-76]
- 2-3 [51-76]
- 4 [102]
- 4 [102]
- 2 [51]
- 3-4 [76-102]
- 2 [51]
- 3-4 [76-102]

(Specify size/type) OUTLET

- ___ IC Inside Caulk
- ___ IG Inside Gasket
- ___ IC Inside Caulk
- ___ IG Inside Gasket
- ___ IP Threaded
- ___ IP Threaded
- ___ NL Neo-Loc
- ___ NL Neo-Loc

'E' BODY HT. DIM.

- 3-1/2 [89]
- 3-1/2 [89]
- 2-3/4 [70]
- 2-3/4 [70]
- 3-1/2 [89]
- 2-3/4 [70]
- 3-7/16 [87]
- 3 [76]

PREFIXES

- ___ Z D.C.C.I. Body and Top*
- ___ ZB D.C.C.I. Body with Polished Bronze Top (Add 3/16 [5] to 1-1/2 [38] or 1-15/16 [48] Dim.)
- ___ ZN D.C.C.I. Body with Polished Nickel Bronze Top (Add 3/16 [5] to 1-1/2 [38] or 1-15/16 [48] Dim.)

SUFFIXES

- ___ -AR Acid Resisting Epoxy Coated Cast Iron
- ___ -DG Duresist Grate
- ___ -F 2 [51] Extension Frame
- ___ -G Galvanized Cast Iron
- ___ -P Trap Primer Connection
- ___ -S Secondary Strainer
- ___ -TC Neo-Loc Test Cap Gasket (2 - 4 [51 - 102] NL Bottom Outlet Only)
- ___ -TS Top Secured with Slotted Screws
- ___ -VP Vandal-Proof Secured Top
- ___ -Y Sediment Bucket

*REGULARLY FURNISHED UNLESS OTHERWISE SPECIFIED

REV. F DATE: 11/15/10 C.N. NO. 120412

DWG. NO. 58923 PRODUCT NO. Z507

ZURN INDUSTRIES, LLC ♦ SPECIFICATION DRAINAGE OPERATION ♦ 1801 Pittsburgh Ave. ♦ Erie, PA 16514

Phone: 814/455-0921 ♦ Fax: 814/454-7929 ♦ World Wide Web: www.zurn.com

In Canada: ZURN INDUSTRIES LIMITED ♦ 3544 Nashua Drive ♦ Mississauga, Ontario L4V1L2 ♦ Phone: 905/405-8272 Fax: 905/405-1292