



Z520

9 [229] ADJUSTABLE HEAVY-DUTY DRAIN

SPECIFICATION SHEET

TAG _____

Dimensional Data (inches and [mm]) are Subject to Manufacturing Tolerances and Change Without Notice

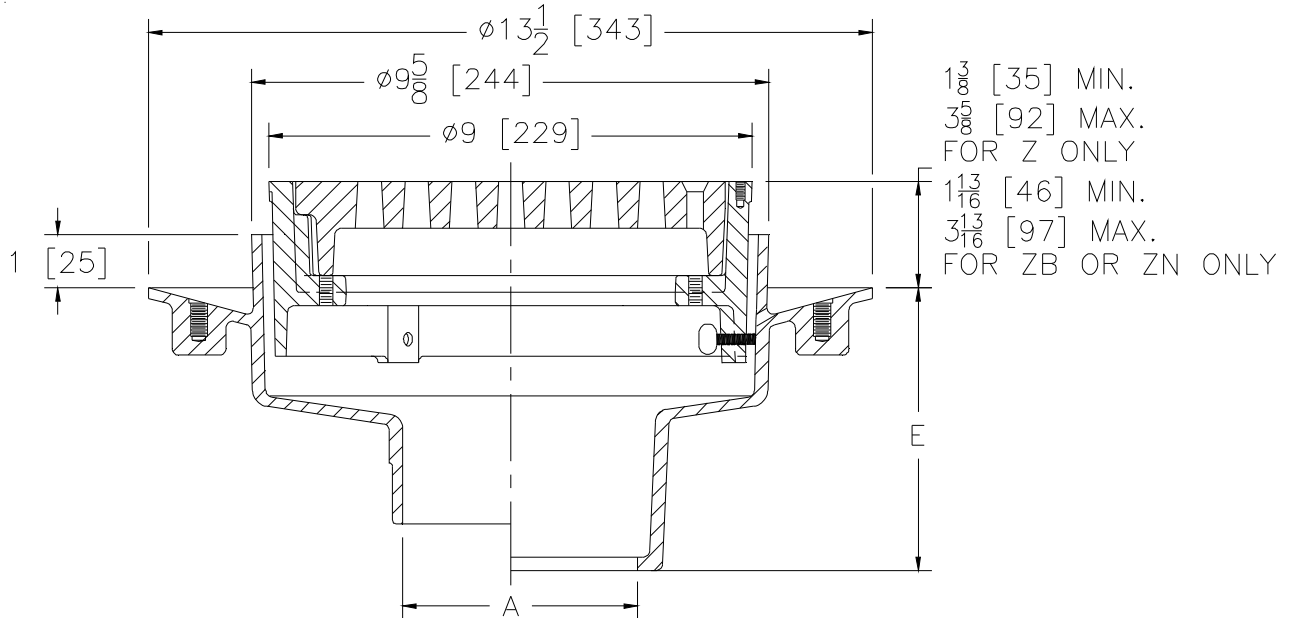

1 ³/₈ [35] MIN.
 3 ⁵/₈ [92] MAX.
 FOR Z ONLY
 1 ³/₈ [46] MIN.
 3 ³/₈ [97] MAX.
 FOR ZB OR ZN ONLY

A Pipe Size In.	Approx. Wt. Lbs. [kg]	Grate Open Area Sq. In. [cm ²]
2-3-4 [51-76-102]	39 [18]	18 [116]
6 [152]	44 [20]	

ENGINEERING SPECIFICATION: ZURN Z520

9 [229] Diameter top drain, Dura-Coated cast iron body with bottom outlet, seepage pan and adjustable extension frame with heavy-duty cast iron deep flange slotted grate.

OPTIONS (Check/specify appropriate options)

PIPE SIZE

- 2 thru 4 [51 thru 102]
- 2 thru 4 [51 thru 102]
- 2 thru 4 [51 thru 102]
- 2 thru 4, 6 [51 thru 102, 152]
- 2 thru 4 [51 thru 102]

(Specify size/type) OUTLET

- ___ IC Inside Caulk
- ___ IG Inside Gasket
- ___ IP Threaded
- ___ NH No-Hub
- ___ NL Neo-Loc

'E' DIM.

- 5-1/4 [133]
- 5-1/4 [133]
- 3-1/2 [89]
- 4-1/4 [108]
- 4-3/8 [111]

PREFIXES

- ___ Z D.C.C.I. Body and Top*
- ___ ZB D.C.C.I. Body w/ Polished Bronze Top (Add 5/8 [16] to 9 [229] Dim.)
- ___ ZN D.C.C.I. Body w/ Polished Nickel Bronze Top (Add 5/8 [16] to 9 [229] Dim.)

SUFFIXES

- ___ -C Clamp Collar
- ___ -DG Duresist Grate
- ___ -F Extension Frame (Specify Total Height Req'd)
- ___ -G Galvanized Cast Iron
- ___ -HP Heel-Proof Grate
- ___ -P Trap Primer Connection
- ___ -S Secondary Strainer
- ___ -SC Solid Cover
- ___ -SG Solid Gasketed Cover
- ___ -SS Stainless Mesh Liner for Bucket
- ___ -T Square Top
- ___ -TC Neo-Loc Test Cap Gasket (2-4 [51-102] NL Bottom Outlet Only)
- ___ -TS Top Secured with Slotted Screws
- ___ -V Backwater Valve (See Z1099)
- ___ -VP Vandal-Proof Secured Top
- ___ -Y Sediment Bucket
- ___ -90 90° Side Outlet (See Z1042)

*REGULARLY FURNISHED UNLESS OTHERWISE SPECIFIED

REV. G DATE: 02/20/13 C.N. NO. 128800

PROD./DWG. NO. Z520

ZURN INDUSTRIES, LLC ♦ SPECIFICATION DRAINAGE OPERATION ♦ 1801 Pittsburgh Ave. ♦ Erie, PA 16514

Phone: 814/455-0921 ♦ Fax: 814/454-7929 ♦ World Wide Web: www.zurn.com

In Canada: ZURN INDUSTRIES LIMITED ♦ 3544 Nashua Drive ♦ Mississauga, Ontario L4V1L2 ♦ Phone: 905/405-8272 Fax: 905/405-1292