



Z526

12 [305] ADJUSTABLE HEAVY-DUTY DRAIN

SPECIFICATION SHEET

TAG _____

Dimensional Data (inches and [mm]) are Subject to Manufacturing Tolerances and Change Without Notice

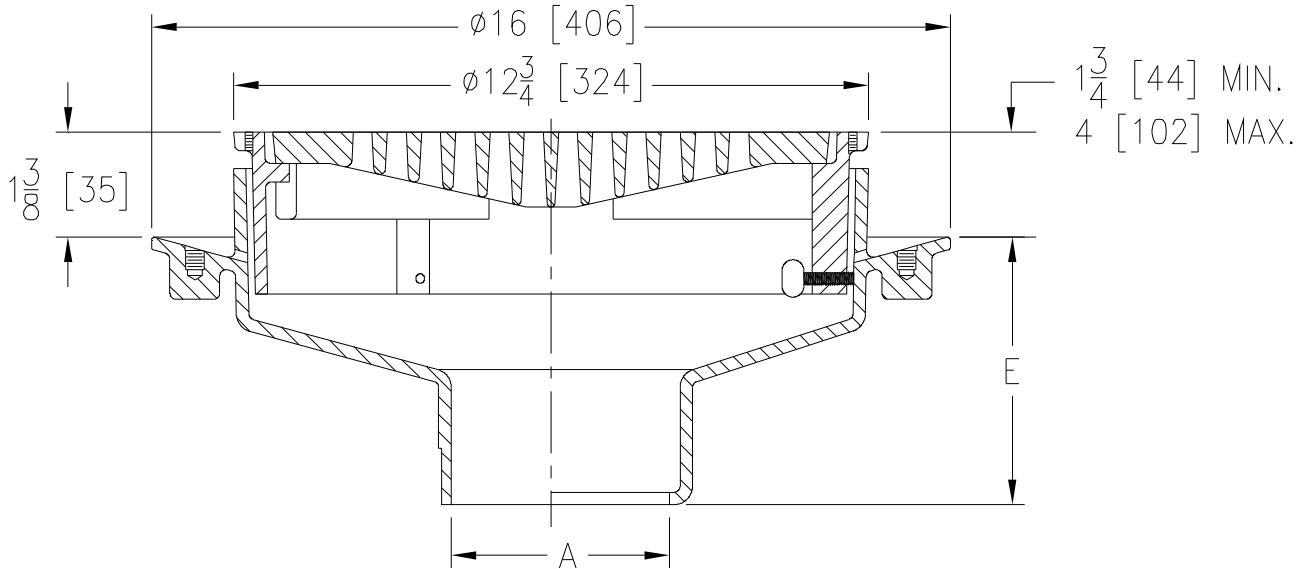

A Pipe Size In.	Approx. Wt. Lbs. [kg]	Grate Open Area Sq. In. [cm ²]
3-4-5-6 [76-102-127-152]	52 [24]	30 [194]

ENGINEERING SPECIFICATION: ZURN Z526

12 [305] Diameter top drain, Dura-Coated cast iron body with bottom outlet, seepage pan, adjustable extension frame and heavy-duty slotted grate.

OPTIONS (Check/specify appropriate options)

PIPE SIZE

- 3 thru 6 [76 thru 152]
- 3, 4 & 6 [76, 102 & 152]
- 4 thru 6 [102 thru 152]
- 4 [102]

(Specify size/type) **OUTLET**

- ___ IC Inside Caulk
- ___ IG Inside Gasket
- ___ IP Threaded
- ___ NL Neo-Loc

'E' BODY HT. DIM.

- 5-3/8 [136]
- 5-3/8 [136]
- 3-3/4 [95]
- 4-5/8 [117]

PREFIXES

- ___ Z D.C.C.I. Body and Top*
- ___ ZB D.C.C.I. Body with Polished Bronze Top (Add 3/16 [5] to 1-3/4 [44] - 4 [102] Dim.)
- ___ ZN D.C.C.I. Body with Polished Nickel Bronze Top (Add 3/16 [5] to 1-3/4 [44] - 4 [102] Dim.)

SUFFIXES

- ___ -C Clamp Collar
- ___ -DG Duresist Grate
- ___ -F Extension Frame
(Specify Total Height Req'd.)
- ___ -G Galvanized Cast Iron
- ___ -HP Heel-Proof Grate
- ___ -S Secondary Strainer
- ___ -T Square Top
- ___ -TC Neo-Loc Test Cap Gasket
(4 [102] NL Bottom Outlet Only)
- ___ -TS Top Secured with Slotted Screws
- ___ -V Backwater Valve (See Z1099)
- ___ -VP Vandal-Proof Secured Top
- ___ -90 90° Side Outlet Body (See Z1042)

REV. D	DATE: 11/16/10	C.N. NO. 120448
DWG. NO. 58933	PRODUCT NO. Z526	

*REGULARLY FURNISHED UNLESS OTHERWISE SPECIFIED

ZURN INDUSTRIES, LLC ♦ SPECIFICATION DRAINAGE OPERATION ♦ 1801 Pittsburgh Ave. ♦ Erie, PA 16514

Phone: 814/455-0921 ♦ Fax: 814/454-7929 ♦ World Wide Web: www.zurn.com

In Canada: ZURN INDUSTRIES LIMITED ♦ 3544 Nashua Drive ♦ Mississauga, Ontario L4V1L2 ♦ Phone: 905/405-8272 Fax: 905/405-1292