



Z531

9 [229] DIAMETER ADJUSTABLE FRAME WIDE FLANGE MEDIUM-DUTY DECK DRAIN

SPECIFICATION SHEET

TAG _____

Dimensional Data (inches and [mm]) are Subject to Manufacturing Tolerances and Change Without Notice

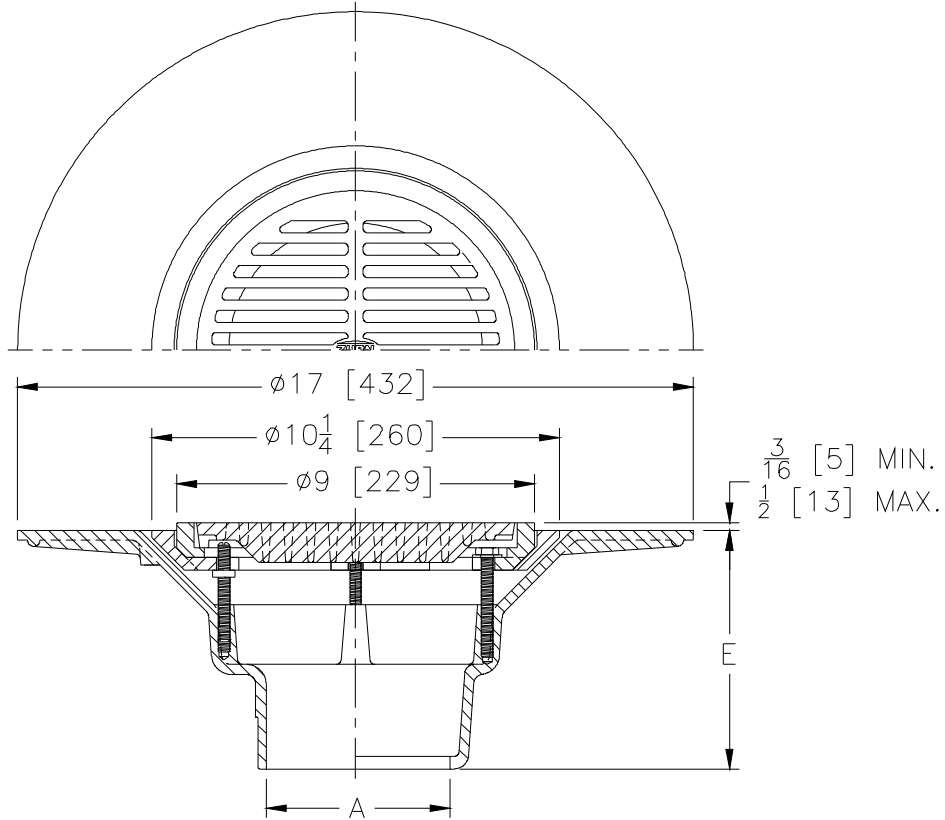

A- Pipe Size In.	Approx. Wt. Lbs. [kg]	Grate Open Area Sq. In. [cm ²]
2-3-4 [51-76-102]	54 [24]	18 [116]

ENGINEERING SPECIFICATION: ZURN Z531

9 [229] Diameter adjustable frame wide flange deck drain, Dura-Coated cast iron body with 10-1/4 [260] diameter latex troweling flange and combination adjustable latex troweling-edge-form and membrane flashing clamp with flat medium-duty grate.

OPTIONS (Check/specify appropriate options)

PIPE SIZE

- 2 thru 4 [51 thru 102]
- 2 thru 4 [51 thru 102]
- 2 thru 4 [51 thru 102]
- 2 thru 4 [51 thru 102]
- 2 thru 4 [51 thru 102]

(Specify size/type) OUTLET

- ___ IC Inside Caulk
- ___ IG Inside Gasket
- ___ IP Threaded
- ___ NH No-Hub
- ___ NL Neo-Loc

'E' BODY HT. DIM.

- 6 [152]
- 6 [152]
- 4-1/2 [114]
- 6 [152]
- 5-3/8 [136]

PREFIXES

- ___ Z D.C.C.I. Body and Top*
- ___ ZB D.C.C.I. Body with Polished Bronze Top
- ___ ZN D.C.C.I. Body with Polished Nickel Bronze Top

SUFFIXES

- ___ -C Underdeck Clamp
- ___ -DG Duresist Grate
- ___ -G Galvanized Cast Iron
- ___ -S Secondary Strainer
- ___ -TC Neo-Loc Test Cap Gasket (2 [51]-4 [102] NL Bottom Outlet Only)
- ___ -TS Top Secured with Slotted Screws
- ___ -VP Vandal-Proof Secured Top
- ___ -Y Sediment Bucket

*REGULARLY FURNISHED UNLESS OTHERWISE SPECIFIED

REV. F	DATE: 6/7/11	C.N. NO. 121379
DWG. NO. 58936	PRODUCT NO. Z531	

ZURN INDUSTRIES, LLC. ♦ SPECIFICATION DRAINAGE OPERATION ♦ 1801 Pittsburgh Ave. ♦ Erie, PA 16514

Phone: 814/455-0921 ♦ Fax: 814/454-7929 ♦ World Wide Web: www.zurn.com

In Canada: ZURN INDUSTRIES LIMITED ♦ 3544 Nashua Drive ♦ Mississauga, Ontario L4V1L2 ♦ Phone: 905/405-8272 Fax: 905/405-1292