

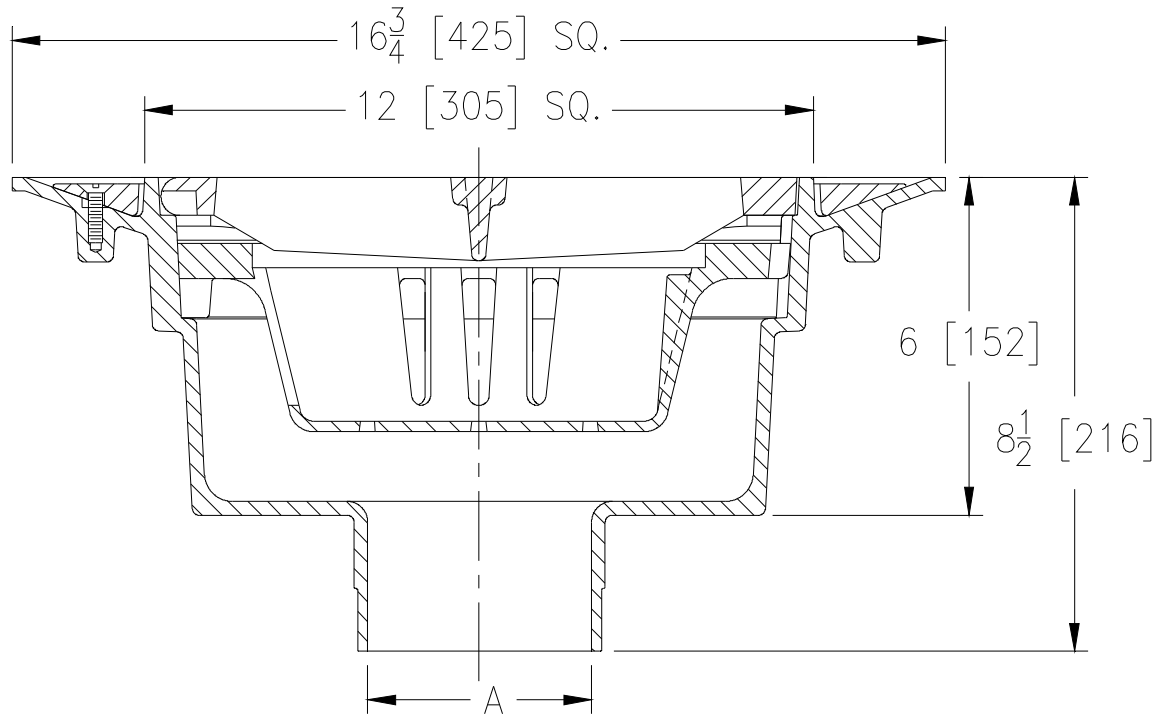

Z535 HEAVY-DUTY PARKING STRUCTURE DRAIN

SPECIFICATION SHEET
TAG _____

Dimensional Data (inches and [mm]) are Subject to Manufacturing Tolerances and Change Without Notice



A Pipe Size In.	Approx. Wt. Lbs. [kg]	Grate Open Area Sq. In. [cm ²]
3-4-6-8 [76-102-152-203]	29 [13]	56 [361]

ENGINEERING SPECIFICATION: ZURN Z535

Square top heavy-duty drain, oven cured acid resistant epoxy coated aluminum body with bottom outlet, top membrane clamping collar, anti-ponding slots, sediment bucket and heavy-duty anti-tilt hinged slotted grate with stainless steel hinge pins.

OPTIONS (Check/specify appropriate options)

PIPE SIZE

3-4-6-8 [76-102-152-203]

(Specify size) **OUTLET**

____ NH No-Hub

PREFIXES

____ Z A.R.C. Aluminum Body and Top*

SUFFIXES

____ -CI Cast Iron Grate
____ -L Locking Device

REV. F	DATE: 7/24/09	C.N. NO. 110003
DWG. NO. 58940		PRODUCT NO. Z535

*REGULARLY FURNISHED UNLESS OTHERWISE SPECIFIED