



**Z539**  
**12 [305] HEAVY-DUTY DRAIN**  
**WITH DEEP SUMP**

SPECIFICATION SHEET

TAG \_\_\_\_\_

Dimensional Data (inches and [ mm ]) are Subject to Manufacturing Tolerances and Change Without Notice

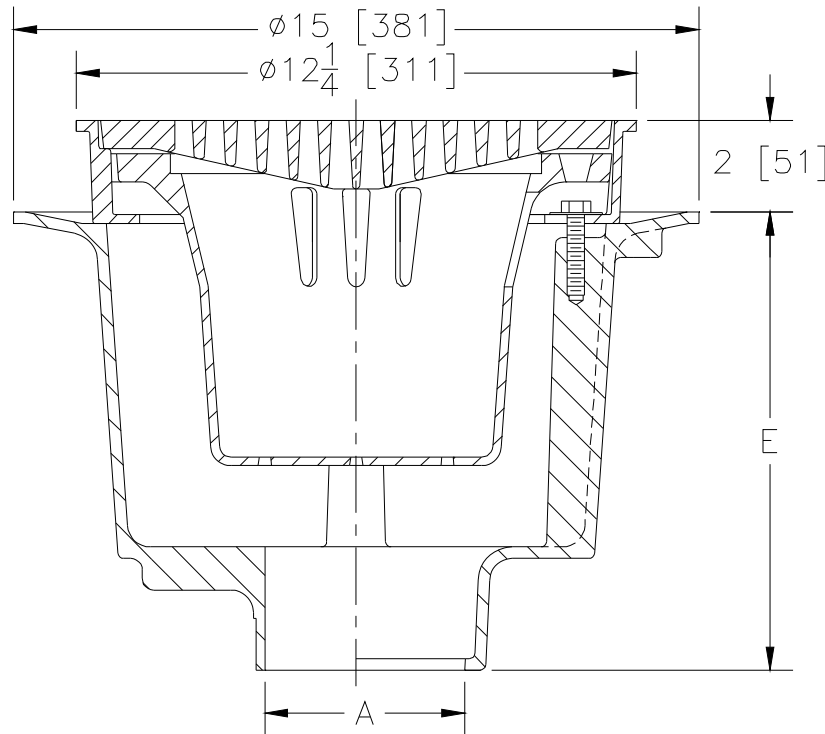

A- Pipe Size In.	Approx. Wt. Lbs. [kg]	Grate Open Area Sq. In. [cm <sup>2</sup> ]
3-4-6 [76-102-152]	68 [31]	30 [194]
8 [203]		

**ENGINEERING SPECIFICATION: ZURN Z539**

12 [305] Diameter top drain, Dura-Coated cast iron deep sump body with bottom outlet, seepage pan and combination membrane flashing clamp and frame for sediment bucket and heavy-duty slotted grate.

**OPTIONS** (Check/specify appropriate options)

PIPE SIZE	(Specify size/type) OUTLET	'E' BODY HT. DIM.
3-4-6 [76-102-152]	___ IC Inside Caulk	10 [254]
3-4-6 [76-102-152]	___ IG Inside Gasket	10 [254]
3-4-6-8 [76-102-152-203]	___ NH No-Hub	10 [254]
3-4 [76-102]	___ NL Neo-Loc	9-5/16 [237]

**PREFIXES**

- \_\_\_ Z D.C.C.I. Body and Top\*
- \_\_\_ ZB D.C.C.I. Body with Polished Bronze Top (Add 3/16 [5] to 2 [51] Dim. and 3/4 [20] to 12-1/4 [311] Dim.)
- \_\_\_ ZN D.C.C.I. Body with Polished Nickel Bronze Top (Add 3/16 [5] to 2 [51] Dim. and 3/4 [20] to 12-1/4 [311] Dim.)

**SUFFIXES**

- \_\_\_ -DG Duresist Grate
- \_\_\_ -G Galvanized Cast Iron
- \_\_\_ -H Hinged Grate
- \_\_\_ -HP Heel-Proof Grate
- \_\_\_ -SS Stainless Steel Mesh Liner for Bucket
- \_\_\_ -T Square Top
- \_\_\_ -TC Neo-Loc Test Cap Gasket (3-4 [76-102] NL Outlets only)
- \_\_\_ -TS Top Secured with Slotted Screws
- \_\_\_ -VP Vandal-Proof Secured Top
- \_\_\_ -YF Free Standing Bucket

\* Regularly furnished unless otherwise specified.