



Z550-TG

9 [229] DIAMETER HEAVY-DUTY DRAIN WITH TRACTOR GRATE

SPECIFICATION SHEET

TAG _____

Dimensional Data (inches and [mm]) are Subject to Manufacturing Tolerances and Change Without Notice

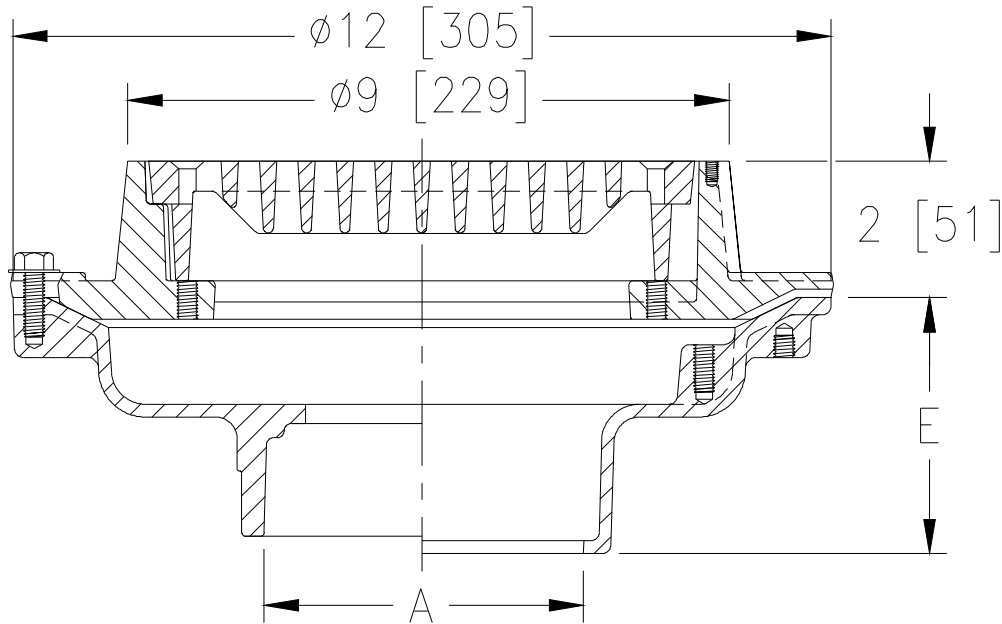

A Pipe Size	Approx. Wt. Lbs. [kg]	Grate Open Area Sq. In. [cm ²]
2-3-4 [51-76-102]	28 [13]	18 [116]
6 [152]	30 [14]	

Engineering Specification:

ZURNZ550-TG

9 [229] Diameter top drain, Dura-Coated cast iron body with bottom outlet, seepage pan, combination membrane flashing clamp, and frame for heavy-duty, cast iron, heel-proof slotted tractor grate.

OPTIONS (Check/specify appropriate options)

PIPE SIZE

- 2, 3, 4 [51, 76, 102]
- 2, 3, 4 [51, 76, 102]
- 2, 3, 4 [51, 76, 102]
- 2, 3, 4 [51, 76, 102]
- 6 [152]
- 2, 3, 4 [51, 76, 102]

OUTLET (Specify size/type)

- ___ IC Inside Caulk
- ___ IG Inside Gasket
- ___ IP Threaded
- ___ NH No-Hub
- ___ NH No-Hub
- ___ NL Neo-Loc

'E' BODY HT. DIM.

- 3-3/4 [95]
- 3-3/4 [95]
- 2-3/4 [70]
- 4-3/4 [121]
- 5-1/4 [133]
- 3-1/2 [89]

PREFIXES

- ___ Z D.C.C.I. Body and Top*
- ___ ZB D.C.C.I. Body with Polished Bronze Top (Add 3/16 [5] to 2 [51] Dim. & 3/4 [20] to 9 [229] Dim.)
- ___ ZN D.C.C.I. Body with Polished Nickel Bronze Top (Add 3/16 [5] to 2 [51] Dim. & 3/4 [20] to 9 [229] Dim.)

SUFFIXES

- ___ -AR Acid Resisting Epoxy Coated Cast Iron
- ___ -C Underdeck Clamp
- ___ -DG Duresist Grate
- ___ -F Extension Frame (Specify Total Height Required)
- ___ -G Galvanized Cast Iron
- ___ -P Trap Primer Connection
- ___ -S Secondary Strainer
- ___ -TC Neo-Loc Test Cap Gasket (2-4 [51-102] NL Bottom Outlet Only)
- ___ -TS Top Secured with Slotted Screw
- ___ -V Backwater Valve (See Z1099)
- ___ -VP Vandal-Proof Secured Top
- ___ -90 90° Threaded Side Outlet Body

* Regularly furnished unless otherwise specified.