



# Z553

## 9-1/2 [241] DIAMETER MEDIUM-DUTY DRAIN

TAG \_\_\_\_\_

Dimensional Data (inches and [ mm ]) are Subject to Manufacturing Tolerances and Change Without Notice

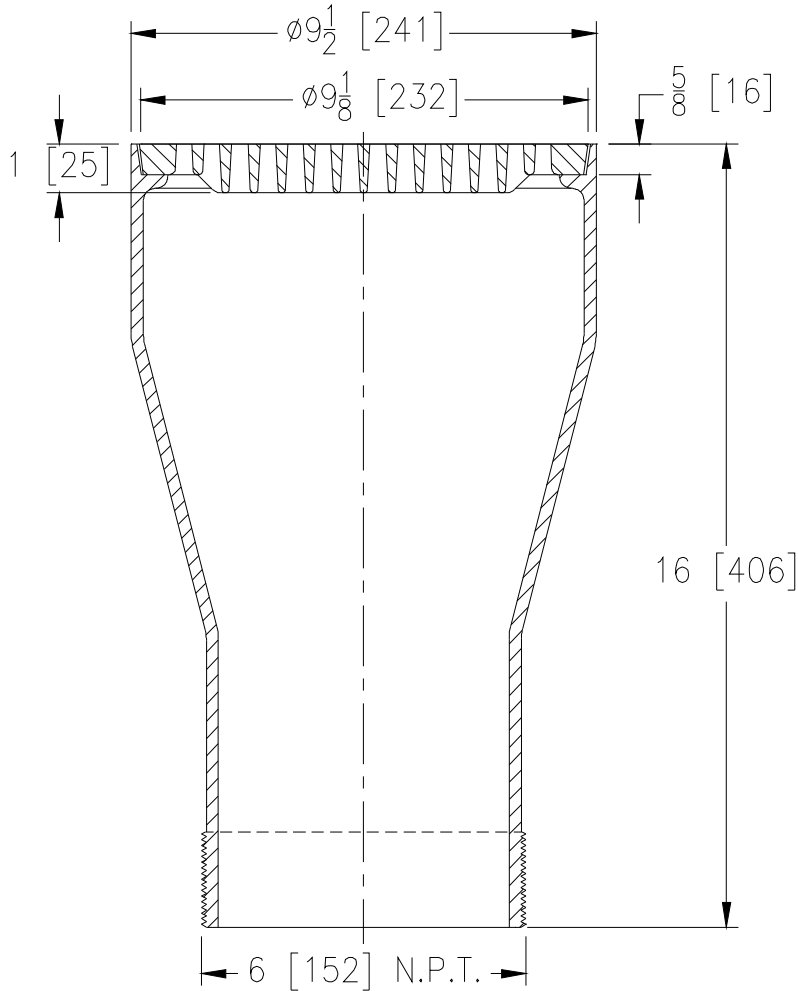

A Pipe Size Inches [mm]	Approx. Wt. Lbs. [kg]	Grate Open Area Sq. In. [cm <sup>2</sup> ]
6 [152]	43 [20]	25 [161]

**ENGINEERING SPECIFICATION: ZURN Z553**  
 9-1/2 [241] Diameter top drain with 6 [152] N.P.T. outlet. Dura-Coated cast iron body with medium-duty 5/16 [8] wide slotted grate.

**OPTIONS** (Check/specify appropriate options)

**PREFIXES**

\_\_\_ Z D.C.C.I. Body and Top\*

**SUFFIXES**

- \_\_\_ -AR Acid Resisting Epoxy Coated Interior
- \_\_\_ -DG Duresist Grate
- \_\_\_ -G Galvanized Cast Iron
- \_\_\_ -K Fabricated Anchor Device
- \_\_\_ -TS Top Secured with Slotted Screws
- \_\_\_ -VP Vandal-Proof Secured Top

<b>REV. B</b>	<b>DATE: 11/16/10</b>	<b>C.N. NO. 120441</b>
<b>DWG. NO. 82461</b>	<b>PRODUCT NO. Z553</b>	

\*REGULARLY FURNISHED UNLESS OTHERWISE SPECIFIED