

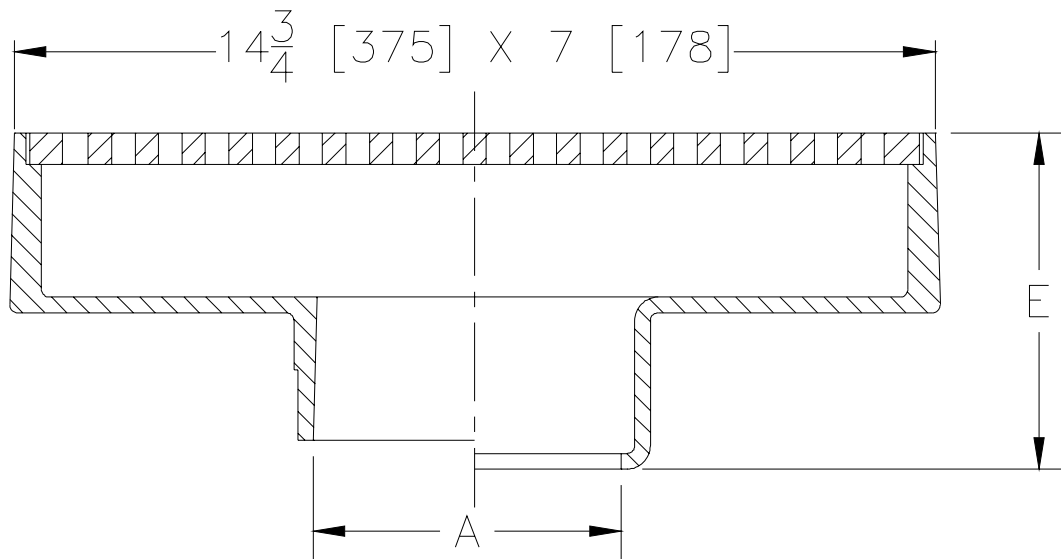

Z576

7 X 15 [178 X 381] MEDIUM-DUTY GUTTER DRAIN

Dimensional Data (inches and [mm]) are Subject to Manufacturing Tolerances and Change Without Notice



A Pipe Size	Approx. Wt. Lbs. [kg]	Grate Open Area Sq. In. [cm ²]
4-5-6 [102-127-152]	30 [14]	39 [252]

ENGINEERING SPECIFICATION: ZURN Z576
 7 x 15 [178 x 381] Top drain, Dura-Coated cast iron body with bottom outlet and medium-duty cast iron anti-tilt slotted grate.

OPTIONS (Check/specify appropriate options)

PIPE SIZE	(Specify size/type) OUTLET	'E' BODY HT. DIM.
4, 5, 6 [102, 127, 152]	___ IC Inside Caulk	5-3/8 [136]
4 [102]	___ IG Inside Gasket	5-3/8 [136]
4, 5, 6 [102, 127, 152]	___ IP Threaded	3-3/4 [95]
4 [102]	___ NH No-Hub (IP w/Z1040)	----
4 [102]	___ NL Neo-Loc	4-5/8 [117]

PREFIXES

- ___ Z D.C.C.I. Body and Top*
- ___ ZB D.C.C.I. Body with Polished Bronze Top (Add 3/16 [5] to E Dim.)
- ___ ZN D.C.C.I. Body with Polished Nickel Bronze Top (Add 3/16 [5] to E Dim.)

SUFFIXES

- ___ -DG Duresist Grate
- ___ -G Galvanized Cast Iron
- ___ -K Seepage Pan
- ___ -KC Seepage Pan With Clamp Collar
- ___ -TC Neo-Loc Test Cap Gasket (4 [102] NL Bottom Outlet Only)
- ___ -TS Top Secured with Slotted Screws
- ___ -V Backwater Valve (See Z1099)
- ___ -VP Vandal-Proof Secured Top
- ___ -WS Wide Slotted Grate (Cast Iron Only)

REV. E	DATE: 04/15/11	C.N. NO. 121163
DWG. NO. 58957	PRODUCT NO. Z576	

*REGULARLY FURNISHED UNLESS OTHERWISE SPECIFIED