



Z665

SPECIFICATION SHEET

**12 [305] WIDE MODULAR TRENCH DRAIN
HEAVY-DUTY**

TAG _____

Dimensional Data (inches and [mm]) are Subject to Manufacturing Tolerances and Change Without Notice

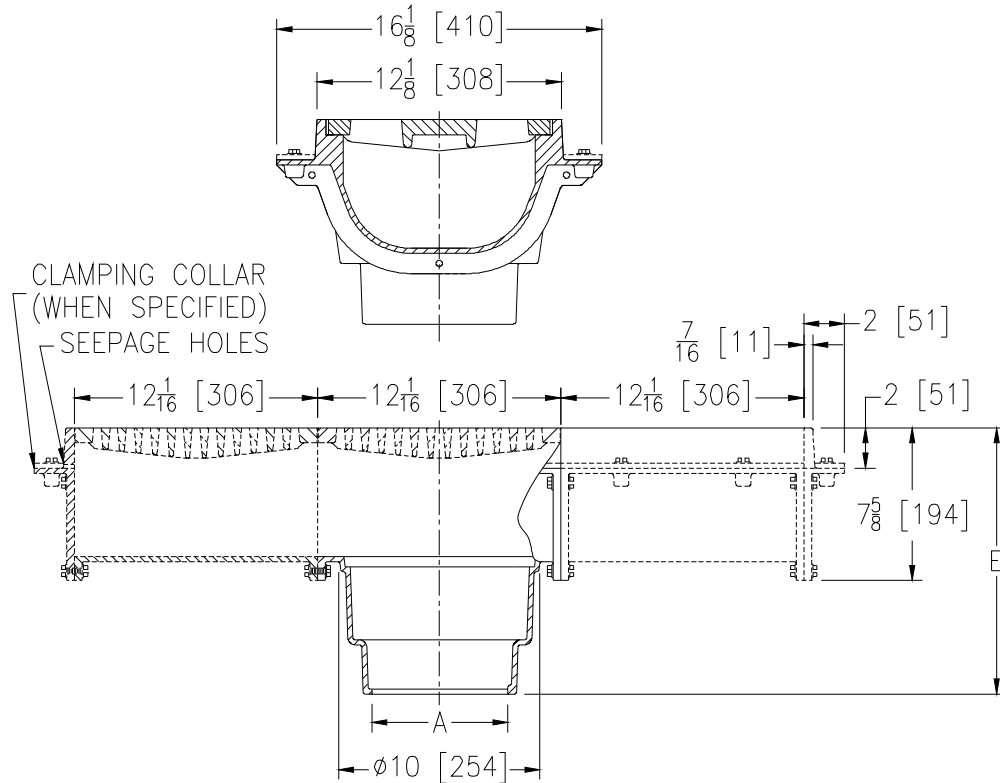

A Pipe Size	Approx. Wt. Lbs. [kg]	Grate Open Area Sq. In. [cm ²]
2, 3, 4 [51, 76, 102]	100 [45]	35 [226]
5, 6 [127, 152]	110 [50]	

ENGINEERING SPECIFICATION ZURN Z665

12 [305] Wide top modular trench drain, Dura-Coated cast iron deep sump body with bottom outlet. Both 12 [305] long outlet module and extension modules are complete with integral seepage pan and heavy-duty loose slotted grate.

OPTIONS (Check/specify appropriate options)

PIPE SIZE

- 2 thru 6 [51 thru 152]
- 2 thru 4, 6 [51 thru 102, 152]
- 2 thru 4 [51 thru 102]

(Specify size/type) **OUTLET**

- _____ IC Inside Caulk
- _____ IG Inside Gasket
- _____ NL Neo-Loc

'E' BODY HT. DIM.

- 13-3/16 [335]
- 13-3/16 [335]
- 12-1/2 [318]

PREFIXES

- _____ Z D.C.C.I. Body and Top*
- _____ ZB D.C.C.I Body w/Polished Bronze Top (Add 1/8 [3] to 'E' and 2 [51] Dim.)
- _____ ZN D.C.C.I Body w/Polished Stainless Steel Top (Add 1/8 [3] to 'E' and 2 [51] Dim.)

SUFFIXES

- | | |
|--|--|
| _____ -AR Acid Resisting Epoxy Coated Cast Iron (Per Section) | _____ -SB Shallow Body (Bucket not Available) |
| _____ -C Clamp Collar (Per Section) | _____ -SQ Square Slotted Medium-Duty Grate |
| _____ -DB Bottom Dome Strainer (Per Outlet Section) | _____ -TC Neo-Loc Test Cap Gasket (2 [51] - 4 [102] NL Bottom Outlet Only) |
| _____ -DG Duresist Grate (Per Section) | _____ -TS Top Secured with Slotted Screws (Per Section) |
| _____ -ES 12 [305] Extension Section (Specify Number of Sections Required) | _____ -VP Vandal-Proof Secured Top (Per Section) |
| _____ -G Galvanized Cast Iron (Per Section) | _____ -Y Sediment Bucket (Per Outlet Section) |
| _____ -HP Heel-Proof Grate (ZB and ZN Only) (Per Section) | |
| _____ -M Side Outlet Adapter Via End Plate | |

*REGULARLY FURNISHED UNLESS OTHERWISE SPECIFIED

REV. G	DATE: 11/8/10	C.N. NO. 120330
DWG. NO. 59250	PRODUCT NO. Z665	

ZURN INDUSTRIES, LLC. ♦ SPECIFICATION DRAINAGE OPERATION ♦ 1801 Pittsburgh Ave. ♦ Erie, PA 16514

Phone: 814455-0921 ♦ Fax: 814454-7929 ♦ World Wide Web: www.zurn.com

In Canada: ZURN INDUSTRIES LIMITED ♦ 3544 Nashua Drive ♦ Mississauga, Ontario L4V1L2 ♦ Phone: 905405-8272 Fax: 905405-1292