



Z668

11 x 19 [279 X 483] HEAVY-DUTY DRAIN

SPECIFICATION SHEET

TAG _____

Dimensional Data (inches and [mm]) are Subject to Manufacturing Tolerances and Change Without Notice

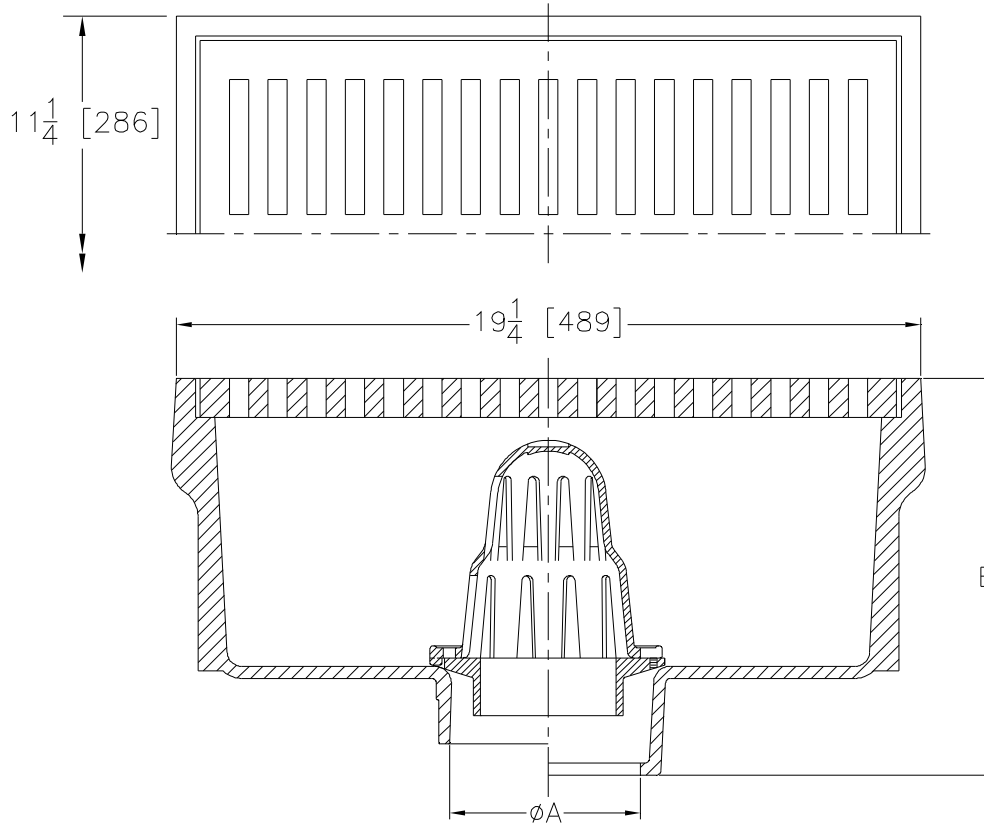

A Pipe Size	Approx. Wt. Lbs. [kg]	Grate Open Area Sq. In. [cm ²]
4, 5, 6 [102, 128, 152]	115 [52]	60 [387]

ENGINEERING SPECIFICATION: ZURN Z668

11 X 19 [279 x 483] top drain, Dura-Coated cast iron body with bottom outlet, less seepage pan, with secondary strainer, loose heavy-duty slotted grate.

OPTIONS (Check/specify appropriate options)

PIPE SIZE

- 4 thru 6 [102 thru 152]
- 4, 6 [102, 152]
- 4 thru 6 [102 thru 152]
- 4 thru 6 [102 thru 152]
- 4 [102]

(Specify size/type) **OUTLET**

- _____ IC Inside Caulk
- _____ IG Inside Gasket
- _____ IP Threaded
- _____ NH No-Hub (IP w/ Z1040)
- _____ NL Neo-Loc

'E' BODY HT. DIM.

- 10-1/4 [260]
- 10-1/4 [260]
- 8-5/8 [219]
-
- 9-1/2 [241]

PREFIXES

- _____ Z D.C.C.I. Body and Top*

SUFFIXES

- _____ -AR Acid Resisting Epoxy Coated Cast Iron
- _____ -DG Duresist Grate
- _____ -G Galvanized Cast Iron
- _____ -TC Neo-Loc Test Cap Gasket
(4 [102] NL Bottom Outlet Only)
- _____ -TS Top Secured with Slotted Screws
- _____ -V Backwater Valve (See Z1099)
- _____ -VP Vandal-Proof Secured Top

*REGULARLY FURNISHED UNLESS OTHERWISE SPECIFIED

REV. E DATE: 11/8/10 C.N. NO. 120332

DWG. NO. 59252 PRODUCT NO. Z668

ZURN INDUSTRIES, LLC. ♦ SPECIFICATION DRAINAGE OPERATION ♦ 1801 Pittsburgh Ave. ♦ Erie, PA 16514

Phone: 814/455-0921 ♦ Fax: 814/454-7929 ♦ World Wide Web: www.zurn.com

In Canada: ZURN INDUSTRIES LIMITED ♦ 3544 Nashua Drive ♦ Mississauga, Ontario L4V1L2 ♦ Phone: 905/405-8272 Fax: 905/405-1292