

# TEMP-GARD™

Pressure Balancing Shower/Tub & Shower Valve  
For Model Series: Z7100, Z7120, Z7200 & Z7220



## □ Installation □ Maintenance Instructions □ Replacement Kits

### INSTALLING THE TEMP-GARD SHOWER VALVE

MAX OPERATING PRESSURE = 125 PSI.

1. Install rough piping and valve body as shown. **Do not use PEX or CPVC CTS piping from valve to tub spout, this causes too much back pressure for valve to function properly.**

- When facing valve, HOT "H" is on left and COLD "C" is on right. Refer to marking on casting when installing. (NOTE: When installing a valve with suffix "RC", the inlets will be reversed.)
- Valve should be installed with the plastic finishing frame lettering face flush with the finish wall. All other trim should be set aside.

**WARNING: Caution should be taken when heating valve for sweat connections to avoid damaging internal rubber and plastic components in valve.**

**FOR OPTIMUM VALVE PERFORMANCE, BALANCE SUPPLY PRESSURES TO LESS THAN 5 PSI PRESSURE DIFFERENTIAL BETWEEN HOT AND COLD WATER SUPPLIES.**

- While finishing tile wall, remove plastic finishing frame and fill area around valve body with grout or plaster.
  - Be careful to keep all ports free of obstructions.
- Turn on both hot and cold supplies and flush out valve.
  - Valve will not operate unless both hot and cold water are turned on.
  - Allow valve to run in warm position for a few minutes to totally flush system. IF SYSTEM IS EXCESSIVELY DIRTY, REMOVE THE CONTROL SPINDLE ASSEMBLY TO ENSURE PROPER FLUSHING.
- Set limit screw as directed by warning below.
- Tighten packing nut(#10) to 15 in. lbs. of torque. Check for desired frictional resistance when rotating handle(#38). Packing nut (#10) can be tightened additionally, in small increments, to increase frictional resistance.
  - Check bonnet, packing nut, diverter spindle o-ring, and all valve, pipe, and fitting connections for leaks.
- Assemble external trim on valve
  - Install escutcheon(#36) (For valves without integral volume or integral volume/diverter controls)
  - Install cover(#31) and dial plate(#32) with (2) cover screws(#35).
  - Remove protective coating from dial plate.
  - Install temperature control handle(#38). (For valves with integral volume or integral volume/diverter controls)
  - Cover(#31) and dial(#32) are to be assembled by sliding diverter/volume control lever handle(#33) into the cover with the diverter clip(#34).
  - Install the assembly with(2) cover screws(#35).
  - Remove protective coating from dial plate.
  - Install temperature control handle(#38).

NOTE: When there is a shutoff valve installed after the control valve, there shall be stop and check valves on the inlets. This is to eliminate hot and cold cross-connection in the event the valve handle is left on. Specify suffix "-SC" for ASSE approved checks.

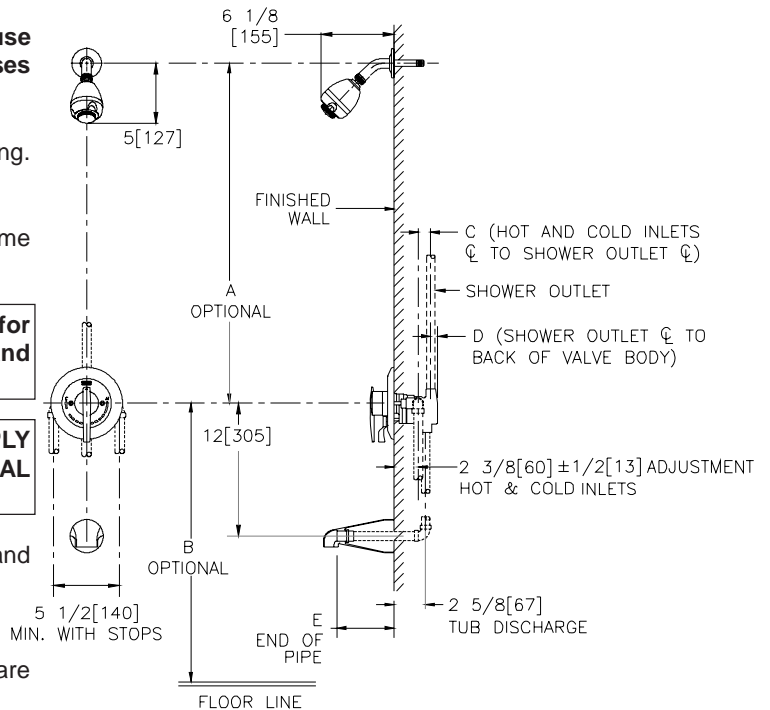

	A	B	C	D	E
Z7100	-	48 inches [1219 mm]	-	5/8 inches [16 mm]	-
Z7101	28 inches [711 mm]	48 inches [1219 mm]	-	5/8 inches [16 mm]	-
Z7120	-	48 inches [1219 mm]	3/4 inches [19 mm]	1/2 inches [13 mm]	-
Z7121	28 inches [711 mm]	48 inches [1219 mm]	3/4 inches [19 mm]	1/2 inches [13 mm]	-
Z7200	-	32 inches [813 mm]	3/4 inches [19 mm]	1/2 inches [13 mm]	-
Z7201	44 inches [1118 mm]	32 inches [813 mm]	3/4 inches [19 mm]	1/2 inches [13 mm]	4 inches [102 mm]
Z7220	-	32 inches [813 mm]	3/4 inches [19 mm]	1/2 inches [13 mm]	-
Z7221	44 inches [1118 mm]	32 inches [813 mm]	3/4 inches [19 mm]	1/2 inches [13 mm]	4 1/4 inches [108 mm]

**WARNING: This shower system may not protect the user from scalding when there is a failure of other temperature controlling devices elsewhere in the plumbing system.**

**WARNING: This product contains lead. A chemical known to the State of California to cause cancer or birth defects or other reproductive harm. Attention plumber/installer: California law requires that this warning be given to the consumer.**

# Maintenance Instructions

## OPERATION

The principal handle of the TEMP-GARD valve is for temperature control only. To turn on the valve, the handle is turned counterclockwise through the cold position, to the warm and then to the hot position. The maximum turn of the valve is approximately one revolution. This large adjustment allows for infinite settings to suit the requirements of the user.

The volume control and volume control/diverter options of the TEMP-GARD valve give the user an added control feature. The shower only valves with volume control; the lever handle below the temperature handle is used to regulate the volume of flow. This is done by moving the lever handle from the far right position (Minimum Flow) to the far left position (Maximum Flow). The tub and shower valves with volume control/diverter; the lever handle below the temperature handle is used not only to regulate the volume of flow but also to divert flow from the tub to the shower. This is done by moving the lever handle to the left for tub flow and to the right for shower flow. Desired volume control is obtained by moving the lever from the vertical position in the required direction. **Do not turn diverter without the complete trim installed. Damage to the diverter spindle may occur if it is turned too far.**

## COVER GASKET

Position gasket in back side of cover with the adhesive against the cover and the open end at bottom as shown.

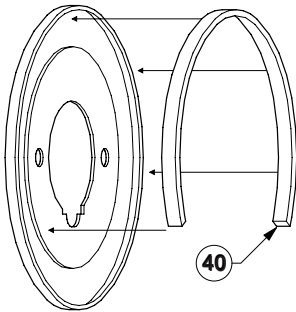

Follow the dimensions below for wall preparation:

- When installing the ZURN TEMP-GARD valve in fiberglass or panel wall (1/16" to 1"), it is recommended to sandwich wall between valve body and the cover (Note: To aid with installation, use the optional wall flange(-WF).)
- On panel walls over 1" thick, install in conventional manner.
- Securing valve piping to rough construction in lieu of full dependence on thin wall for rigidity is recommended.

## SERVICE (REFER TO FINAL PAGE FOR PART CALL-OUTS)

1. Shut-off water to valve with service stops. To do this remove both retainer screws (#26) with flathead screwdriver. Then turn both service stop spindles (#22) clockwise with 3/16" Allen wrench.
2. Remove cover trim.
3. **Caution Important:** Before removing bonnet (#3) follow this sequence to avoid distortion of stem. Back out adjustment screw Item (#8) until O-ring is fully exposed. **Open valve to full hot** and unscrew bonnet (#3). Control stem will be removed with bonnet. Leave packing nut (#10) in place when removing bonnet to avoid distortion of control stem.

(Note: Leave packing nut(#10) in place and valve in full hot position when removing bonnet to avoid distortion to control stem)

4. Standard service: To eliminate dripping or non-positive off.
  - This normally requires only the replacement of parts supplied in control stem washer replacement kit(RK7000-120) or stem replacement kit(RK7000-50).
  - Hold control stem with temperature handle(#38) to remove the hot washer retaining screw(#17) and the cold washer retaining ring(#13). Channel locks or equivalent can be used to remove cold washer retaining ring.

(Note: Be sure to inspect seats, seat o-ring and control stem for wear)

5. Extended service: When wear on seats, seat o-ring or control stem is identified.
    - 5a Seat replacement
      - Requires seat replacement kit(RK7000-180) and a set of seat tools(RK7000-18TOOLS)(Note: Make a positive engagement of tool into seats while removing and reassembling.)
    - 5b Control stem assembly service and replacement.
      - The inside end of the control stem going into the valve is the most critical part of the valve. This end houses the stainless steel control piston.
      - If the piston is obstructed or blocked, first soak the control stem assembly overnight in household vinegar. Then try to free it by tapping the handle end against a firm object such as a stiff rubber handle or the sole of a shoe. If piston comes free, shake it and feel for resistance. The piston should move freely in control stem and should "click" when assembly is shaken.
      - If piston does not become unobstructed or any damage is noted, replace it with the control stem assembly (RK7000-50).
        - Loosen packing nut prior to inserting new control stem, as this reduces possible damage to packing components.
        - Lubricate control stem shaft threads with included pillow packet lube, prior to inserting in bonnet.
- DO NOT TAMPER WITH THE CONTROL SPINDLE OR ATTEMPT TO REMOVE THE PISTON.**

6. Reassemble the ZURN TEMP-GARD valve.
  - Reversing above procedure; **IMPORTANT: Be sure that the spindle assembly is drawn close to the bonnet before screwing bonnet back into valve.**
  - Tighten bonnet to 25 ft. lbs. of torque.
  - Tighten packing nut to 15 in. lbs. of torque, and check for desired frictional resistance when rotating handle. Packing nut can be tightened additionally, in small increments, to increase frictional resistance.
  - Reset adjustment screw to obtain maximum desired output temperature.
  - Check for leaks, prior to reinstalling trim.

# Maintenance Instructions

PROBLEM	CAUSE	SOLUTION
Valve will not flow water.	Hot and cold water not turned on. Service Stops not open.	Be sure both supplies are turned on and service stops are open. Valve will not operate unless both HOT and COLD water inlets have pressure.
Valve leaks when shut-off.	Hot and cold water washers are worn, or foreign matter (solder, chips, etc.) are between washers and seat surfaces.	Replace Hot and Cold washers and inspect top surface on hot and cold seats for damage.
Water volume from valve is inconsistent during operation.	Pressure balancing piston housed in control spindle assembly is blocked from free movement by foreign matter.	With valve open half way, remove temperature handle and tap spindle with plastic hammer. If problem is not solved, remove spindle assembly completely and tap handle end against a solid object to free piston. Rinse out control sample assembly. Soaking in household vinegar will help free foreign debris matter buildup.
Valve delivers an insufficient quantity of Hot or Cold water.		
Temperatures fluctuates without moving temperatures handle.		
Temperatures out of valve reduces gradually during use.	Supply system is running out of hot water.	Reduce maximum flow rate out of valve or shower head. This will allow longer period of use before reduction of hot water supply.
While using a tub & shower valve with integral diverter set for shower, a trickle of water runs from tub spout.	This is a design function of the valve. Water is allowed to trickle from the tub spout when diverter is set in shower position; in accordance to national standards.	
Valve makes loud noise.	Piston in stem is moving back and forth because of a large pressure differential between the HOT and COLD water lines.	Alter the water system such that the pressure differential at all shower valves is no more than 5 psi.

## Back to Back Installation Drawings

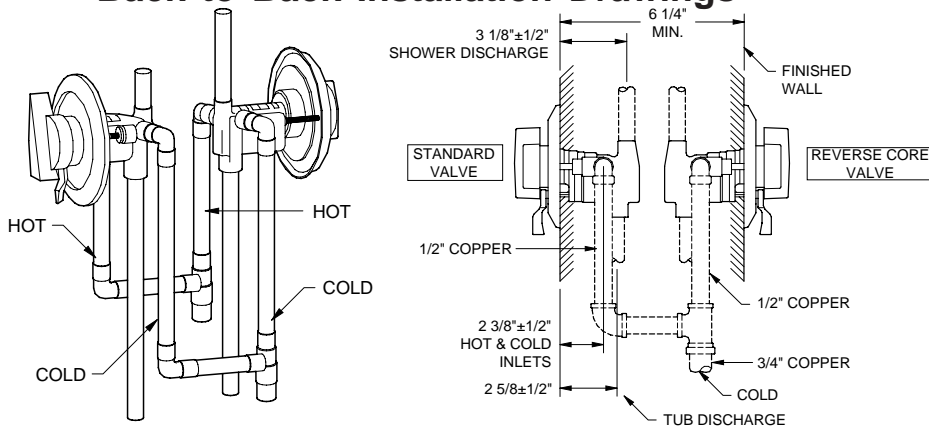

The ZURN TEMP-GARD Pressure Balancing Shower Valve is equipped with an adjustable limit stop screw. The limit stop device is to be used to limit the valve handle from being turned to undesired hot water discharge temperatures. To adjust the limit stop screw, remove handle and escutcheon, turn valve to maximum desired temperature and turn the limit stop screw until it seats.

**IMPORTANT: Failure to adjust the limit stop screw properly increases the chances for serious injury.**

**NOTE:** It is recommended that when any TG1 shower valve is first installed on a new large system or in an excessively dirty system, that the hose bibb flushing out kit (RK7000-20HB) be used to clean the valve of debris from the installation of the water system. To do this, remove the spindle assembly per the service instructions and replace with the hose bibb bonnet nut. Attach a garden hose to the bibb to direct the water to a drain. Open both service stops and allow the water to run for several minutes. Once the system is completely flushed out, replace the hose bibb with the spindle assembly. Open valve to flush out any debris that may be in the spindle.

**NOTE:** If the shower valves are going to remain unused for an extended period of time (over 3 months) then the water should be shutoff to the valves (via service stops or system control valve) and each valve should be opened to allow the water in the valve to evaporate. This is to keep the piston from sticking, due to stagnant or hard water, once the valve is in use again. If piston does stick, soak the valve assembly in vinegar per the maintenance instructions.

# Replacement Kits

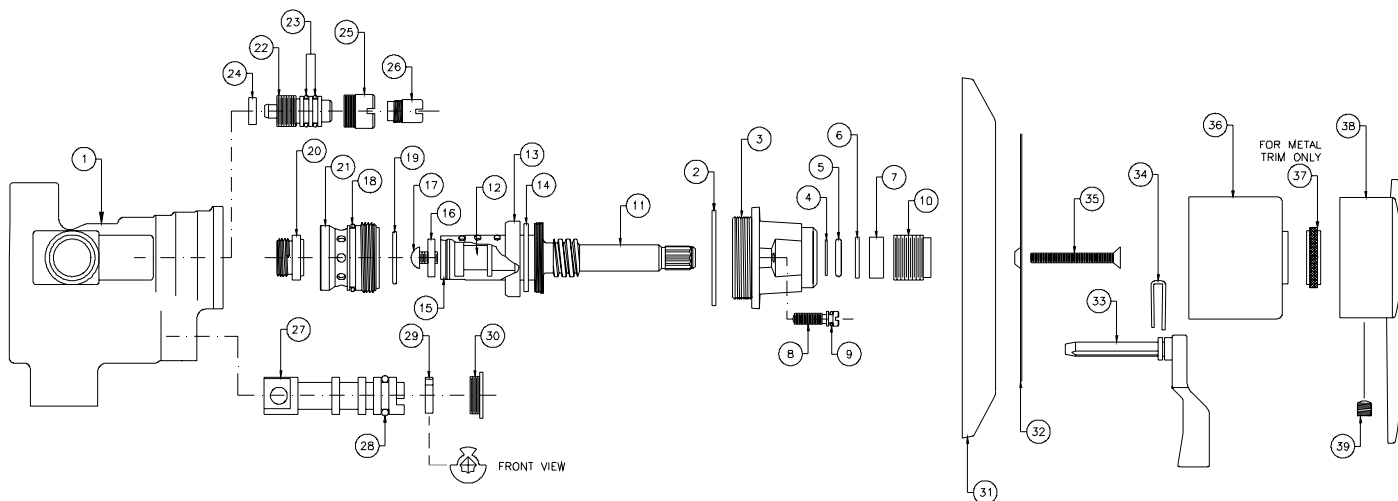

## RK7000-50 CONTROL STEM REPLACEMENT KIT

ITEM NO.	
2	CAP GASKET
11	CONTROL STEM
12	CONTROL PISTON
13	COLD WASHER RETAINER
14	COLD WASHER
15	CONTROL PISTON PLUNGER
16	HOT WASHER
17	WASHER RETAINING SCREW

## RK7000-50A SERVICE STOP REPLACEMENT KIT (2) PER

ITEM NO.	
22	VALVE STOP
23	STOP O-RING
24	STOP GASKET

## RK7000-50BN DIVERTER/VOLUME CONTROL SPINDLE REPLACEMENT KIT

ITEM NO.	
27A	DIVERTER SPINDLE (WHITE W/ BLACK GASKET)
28	O-RING
29	DIVERTER KEY

## RK7000-50C VOLUME CONTROL SPINDLE REPLACEMENT KIT

ITEM NO.	
27B	DIVERTER SPINDLE (BLACK)
28	O-RING
29	DIVERTER KEY

## RK7000-100 PACKING REPLACEMENT KIT

ITEM NO.	
2	CAP GASKET
4	O-RING WASHER
5	O-RING
6	PACKING WASHER
7	GRAPHITE PACKING

## RK7000-110 ADJUSTMENT SCREW REPLACEMENT KIT

ITEM NO.	
8	ADJUSTMENT SCREW
9	O-RING

## RK7000-120 CONTROL STEM WASHER REPLACEMENT KIT

ITEM NO.	
2	CAP GASKET
13	COLD WASHER RETAINER
14	COLD WASHER
16	HOT WASHER
17	WASHER RETAINING SCREW

## RK7000-180 SEAT REPLACEMENT KIT

ITEM NO.	
18	COLD SEAT O-RING
19	INT. COLD SEAT O-RING
20	HOT WATER SEAT
21	COLD WATER SEAT

## PARTS:

1	BODY	23	SERVICE STOP O-RING
2	CAP GASKET	24	STOP GASKET
3	BONNET	25	STOP RETAINER(7000-3D)
4	O-RING WASHER	26	RETAINER SCREW(7000-11D)
5	O-RING	27A	DIV/VOL CONTROL SPINDLE
6	PACKING WASHER	27B	VOLUME CONTROL SPINDLE
7	GRAPHITE PACKING	28	DIVERTER SPINDLE O-RING
8	ADJUSTMENT SCREW	29	DIVERTER KEY
9	ADJUSTMENT SCREW O-RING	30	DIVERTER RETAINER(7000-3)
10	PACKING NUT	31A	COVER, ABS(7000-8)
11	CONTROL STEM	31B	COVER, BRASS(7000-8MT)
12	CONTROL PISTON	32A	DIAL, STANDARD(T7000)
13	COLD WASHER RETAINER	32B	DIAL, DIV/VOL CONTROL(T7001)
14	COLD WASHER	32C	DIAL, VOLUME CONTROL(T7001A)
15	CONTROL SPINDLE PLUNGER	33	DIVERTER HANDLE(7000-6C)
16	HOT WASHER	34	CLIP(7000-32)
17	WASHER RETAINING SCREW	35	COVER SCREW(7000-11AB)
18	COLD SEAT O-RING	36A	ESCUTCHEON, ABS(7000-81)
19	INT. COLD SEAT O-RING	36B	ESCUTCHEON, BRASS(7000-81MT)
20	HOT WATER SEAT	37	ESCUTCHEON NUT(7500-9)
21	COLD WATER SEAT	38	TEMPERATURE HANDLE, METAL
22	SERVICE STOP SPINDLE	39	HANDLE SETSCREW(7000-11G)
		40	COVER GASKET (SEE COVER GASKET INSTALLATION)

## RK7000-200 CAP REPLACEMENT KIT

ITEM NO.	
2	CAP GASKET
3	BONNET
4	O-RING WASHER
5	O-RING
6	PACKING WASHER
7	GRAPHITE PACKING
8	ADJUSTMENT SCREW
9	ADJUSTMENT SCREW O-RING
10	PACKING NUT

## RK7000-18TOOLS SEAT REPLACEMENT KIT

ITEM NO.	
	COLD SEAT TOOL
	HOT SEAT TOOL

## Z7000-LH HANDLE ASSEMBLY

ITEM NO.	
38	TEMP HANDLE, METAL
39	HANDLE SET SCREW (7000-11G)

Proper performance is dependent upon licensed, qualified personnel performing regular, periodic testing according to ZURN specifications and prevailing governmental & industry standards and codes and upon following these installation instructions. Failure to do so releases ZURN of any liability that it might otherwise have with respect to that device. Such failure could also result in an improperly functioning device.

ZURN INDUSTRIES, LLC. ♦ COMMERCIAL BRASS OPERATION ♦ 5900 ELWIN BUCHANAN DRIVE ♦ SANFORD NC 27330  
Phone: 1-800-997-3876 ♦ Fax: 919-775-3541 ♦ World Wide Web: www.zurn.com  
In Canada: ZURN INDUSTRIES LIMITED ♦ 3544 Nashua Drive ♦ Mississauga, Ontario L4V1L2 ♦ Phone: 905-405-8272 Fax: 905-405-1292

Form # CF1007 Date: 12/27/11 Product # IS7000  
C.N. No. 128455 Rev. J Sheet: 4 of 4