



4" CENTERSET GOOSENECK

Z812A1

TAG _____



Engineering Specifications: Zurn AquaSpec® Z812A1

Polished chrome-plated cast brass faucet body with integral shanks, quarter turn ceramic disc cartridges and a 3-1/2" [89mm] centerline rigid or swing gooseneck spout. Unit is furnished with a 2.2 GPM [8.3 L] pressure compensating aerator (complying with ANSI A112.18.1 Standard for flow), 2-1/2" [64mm] vandal-resistant color-coded metal lever handles, mounting hardware and 1/2" NPSM coupling nuts for standard lavatory risers.

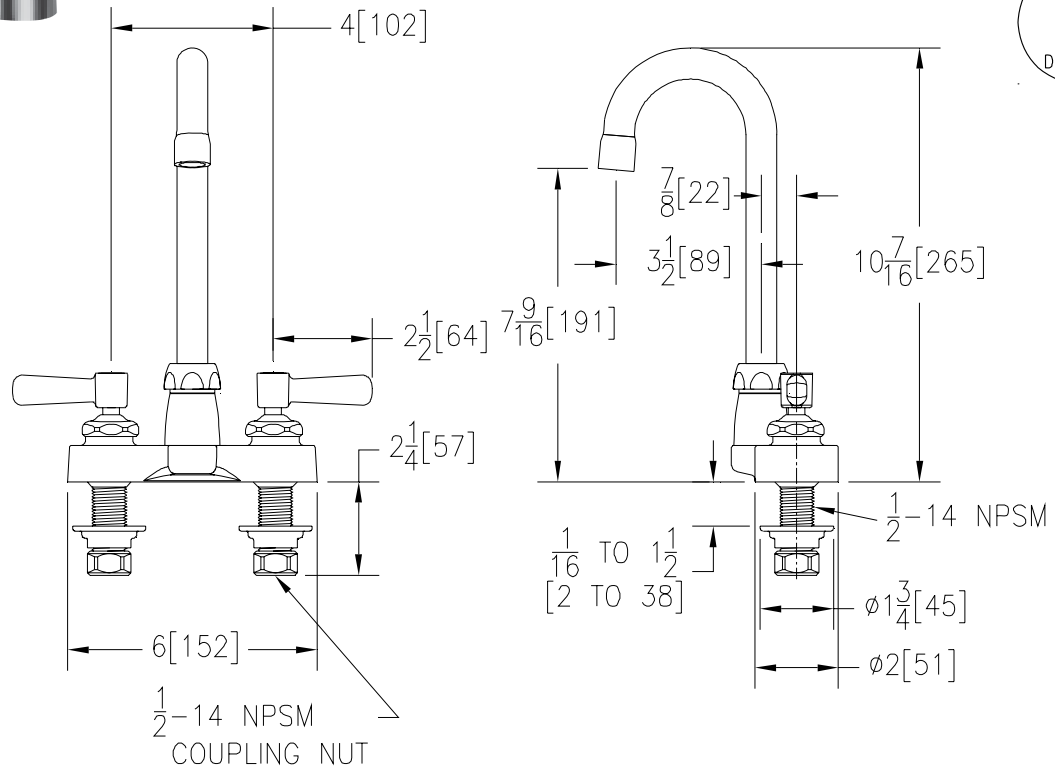

Note: All dimensions are for reference only. Do not use for pre-plumbing.

OPTIONAL ACCESSORIES

Suffix Description

Suffix	Description
___-FC	2.0 GPM [7.6 L] Laminar Flow Control in Base of Spout
___-G	1-1/4" [32mm] Grid Strainer Drain
___-HCT	Hot/Cold Text Indexes
___-P	1-1/4" [32mm] Pop-up Drain
___-PT	1-1/4" [32mm] Cast Brass P-Trap with a 7-1/2" [191mm] Long 17-Gauge Wall Bend
___-2F	2.2 GPM [8.3 L] Vandal-Resistant Pressure Compensating Female Aerator
___-3F	0.5 GPM [1.9 L] Vandal-Resistant Pressure Compensating Female Aerator
___-4F	2.2 GPM [8.3 L] Vandal-Resistant Pressure Compensating Female Laminar Flow
___-5F	2.0 GPM [7.6 L] Female Spray Outlet
___-7F	1.0 GPM [3.8 L] Pressure Compensating Female Spray Outlet
___-16F	1.0 GPM [3.8 L] Vandal-Resistant Pressure Compensating Female Spray Outlet
___-17F	1.5 GPM [5.7 L] Vandal-Resistant Pressure Compensating Female Aerator
___-18F	1.5 GPM [5.7 L] Vandal-Resistant Pressure Compensating Female Laminar Flow

ZURN INDUSTRIES, INC. ♦ COMMERCIAL BRASS OPERATION ♦ 2640 SOUTH WORK STREET ♦ FALCONER NY 14733

Phone: 1-716-665-1132 ♦ Fax: 1-716-665-1135 ♦ World Wide Web: www.zurn.com

In Canada: ZURN INDUSTRIES LIMITED ♦ 3544 Nashua Drive ♦ Mississauga, Ontario L4V1L2 ♦ Phone: 905/405-8272 Fax: 905/405-1292