

Engineering Specification: Zurn AquaSpec® Z842X1-AF

Polished chrome plated cast brass 8" [203mm] pre-rinse faucet with quarter turn ceramic disc cartridges, 3/8" [10mm] short swivel inlets with check stops providing adjustable centers from 7-1/4" [184mm] to 8-3/4" [222mm] and 2-1/2" [64mm] vandal resistant color-coded metal lever handles. Unit is furnished with a single valve Adapta faucet with a 9-1/2" [241mm] swing spout and single screen outlet, a 24" [610mm] riser with a 36" [914mm] stainless steel spring hose, a 1.6 GPM @ 60 psi (6.1 l/min. @ 400 kPa) self-closing pre-rinse hand held valve with an insulated handle, a stay open clip, a protective bumper spray head, a wall mounted pipe support and a hose hook.

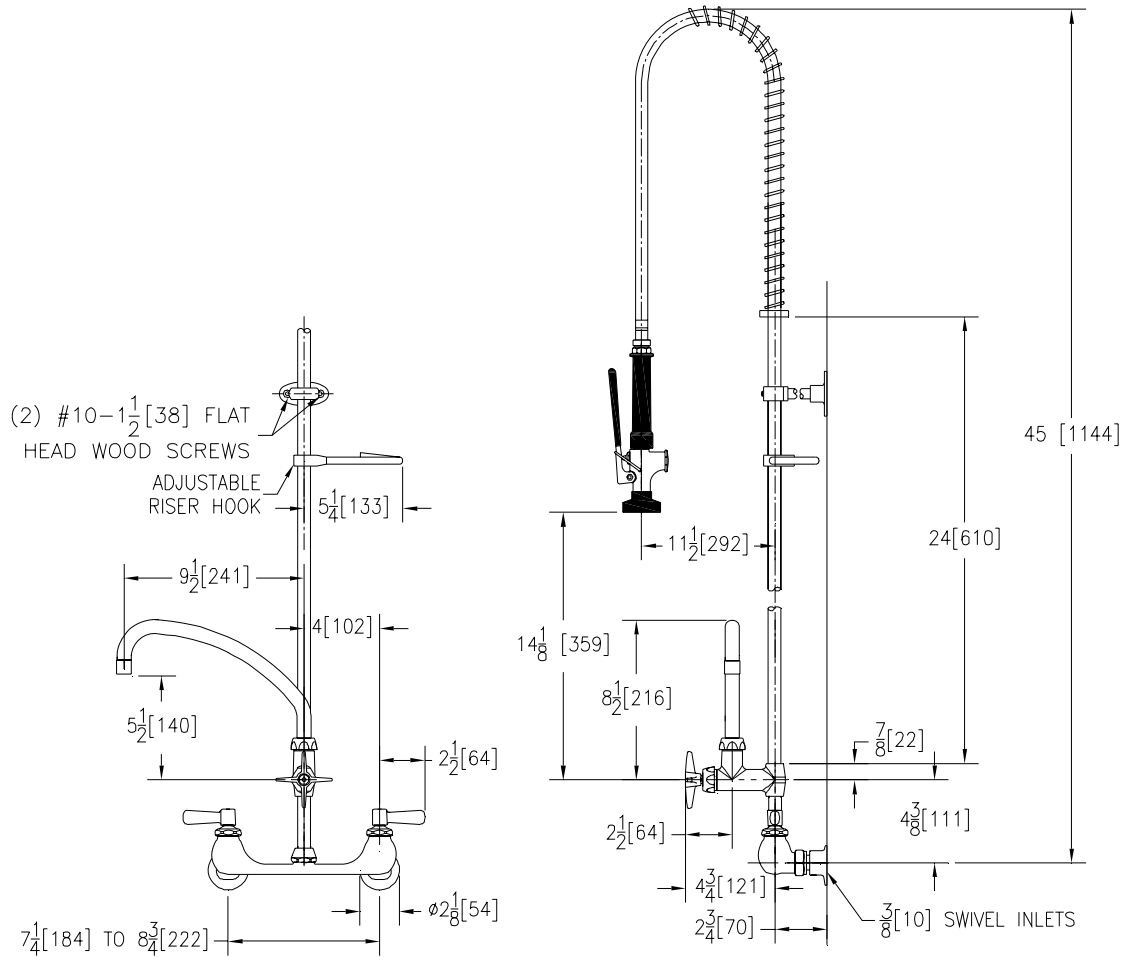

Note: All dimensions are for reference only. Do not use for pre-plumbing.

OPTIONAL ACCESSORIES

Suffix	Description
___ -HCT	Hot/Cold Text Indexes
___ -LSI	2-1/2" [64mm] Long Swivel Inlets with Integral Stops
___ -PR2	Pre-Rinse with Angle Spray Head, Rubber Bumper Spray Outlet and Self-closing Valve
___ -PR3	Pre-Rinse with Angled Aerated Outlet and Self-closing Valve
___ -RC	Rough Chrome Plated

ZURN INDUSTRIES, LLC ♦ COMMERCIAL BRASS OPERATION ♦ 2640 SOUTH WORK STREET ♦ FALCONER NY 14733

Phone: 1-800-997-3876 ♦ Fax: 1-919-775-3541 ♦ www.zurn.com

In Canada: ZURN INDUSTRIES LIMITED ♦ 3544 Nashua Drive ♦ Mississauga, Ontario L4V1L2 ♦ Phone: 905/405-8272 Fax: 905/405-1292